

THE BROADCAST ENGINEERS' JOURNAL
ED. STOLZENBERGER, EDITOR
116-03 91ST AVENUE, RICHMOND HILL 18, N. Y.

POSTMASTER: IF UNDELIVERABLE FOR ANY
REASON, NOTIFY SENDER, STATING REASON,
ON FORM 3547, POSTAGE FOR WHICH IS
GUARANTEED

F A GEHRES WGBF-WEQA
2232 E POWELL
EVANSVILLE 14 IND
\$148

Sec. 562, P. L. and R

U. S. POSTAGE

PAID

New York, N. Y.

Permit No. 2961

OFFICIAL PUBLICATION OF THE NATIONAL ASSOCIATION OF BROADCAST ENGINEERS AND TECHNICIANS

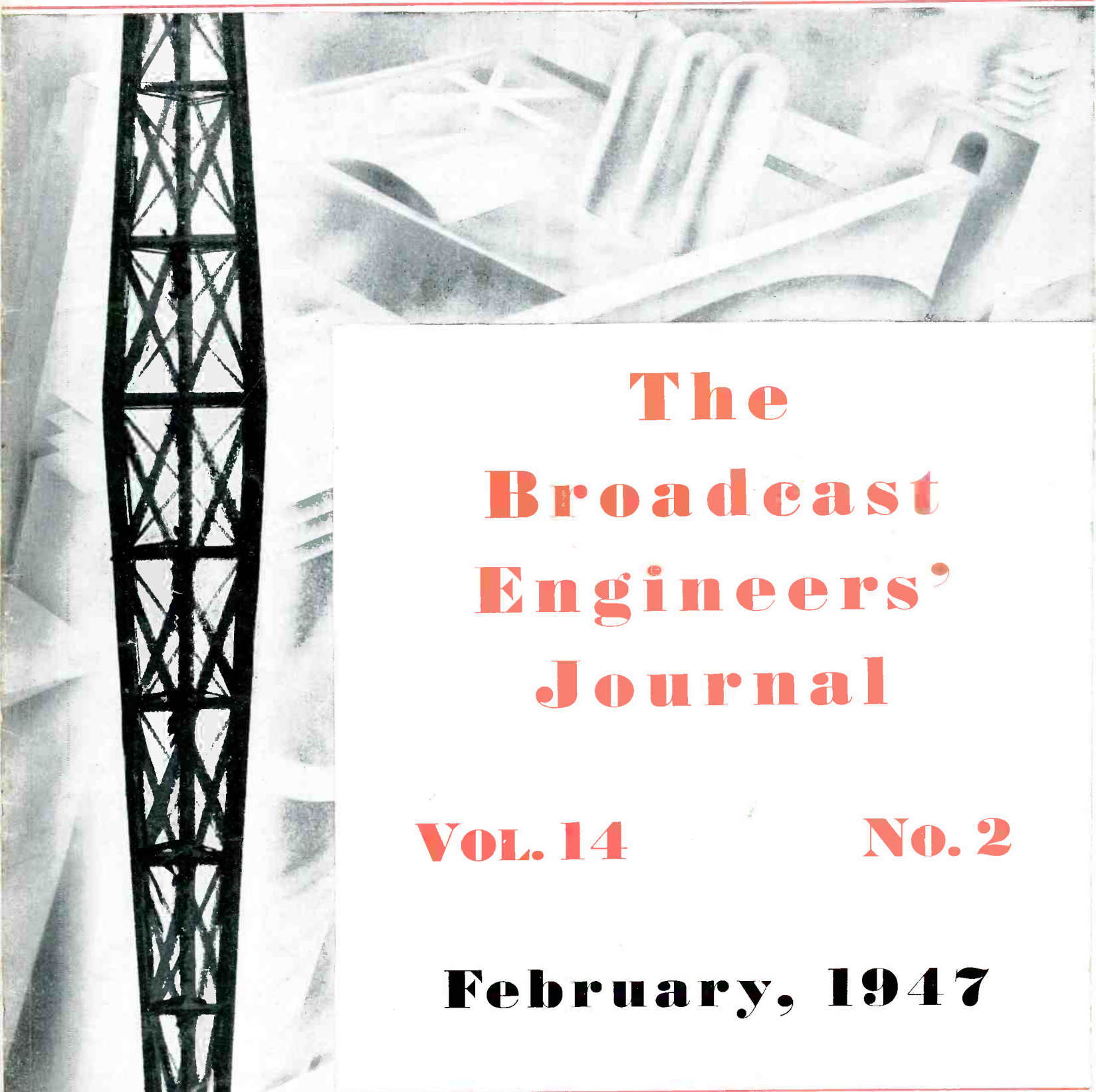

The Broadcast Engineers' Journal

VOL. 14

No. 2

February, 1947

SINCE 1934 -- OF, BY, AND FOR THE BROADCAST ENGINEER

A Major Advancement in the Recording Blank Field . . .

10 Year Guarantee

**GOULD-MOODY PROFESSIONAL QUALITY "BLACK SEAL"
ALUMINUM INSTANTANEOUS RECORDING BLANKS
AT NO INCREASE IN PRICES!**

After prolonged research and experimentation, we have introduced technological improvements into "Black Seal" blanks that not only increase the life span, but materially enhance the other fine characteristics of these blanks. And so positive are we of the performance of these perfected "Black Seals" that we've placed an unconditional guarantee of ten years on each one of them.

What Does This Guarantee Mean to You?

It means that Gould-Moody "Black Seal" blanks will not rip up, disintegrate or powder after the first playing if kept in storage for any long period of time. It means that atmospheric conditions and changes, moisture and dampness, and old age will have no effect on blanks bearing "Black Seal" labels. It means that you'll be in no danger of losing valuable recordings in what, up until now, you have considered your safe library of recordings. And it means that you can expect the finest reproduction from the finest blank you have ever had on your turntable.

You Can't Afford To Be A Recording Isolationist

Whether you're a recording engineer in New York, Burbank or Wichita . . . no matter how well satisfied you are with your present blanks — you can't afford to be a recording isolationist now. Try these new Gould-Moody "Black Seal" blanks. Cut a few. If, for any reason whatsoever, you do not like them, you can return them at our expense.



**GOULD-MOODY'S PREFERRED RESHARPENING SERVICE
restores the point on your precious recording needle
SAPPHIRE! STELLITE!**

Exact workmanship assures lower surface noise and longer wear. In fact, needles and styli refinished by Gould-Moody are frequently reported to last longer than the original points. And the extreme accuracy with which that last 3/1000ths of an inch is shaped enables the needle to fit with microscopic perfection into the groove, thereby reducing record wear to minimum. This saving, in many cases, exceeds the cost of Gould-Moody resharpening.

THE GOULD-MOODY COMPANY

RECORDING BLANK DIVISION

395 BROADWAY, NEW YORK 13, N. Y.

... apologies to **CFPA** and **WAGM**

Perhaps you remember, some time ago, our advertising lads worked up an illustration showing a map with pins indicating that more than 750 radio broadcast stations use the Shure 556.

A thousand miles apart . . . two men scanned the map . . . found their locations. "What! no pin." Then came letters from Harold D. Glidden, General Manager of WAGM, up in Maine and Ralph H. Parker of CFPA at Port Arthur, Ontario.

... says Harold Glidden . . . "our pair of 556's are operating very satisfactorily."

... says Ralph Parker . . . "our two 556's are doing a swell job."

... say we . . . "two more pins for two more good customers."

... yours, **SHURE BROTHERS**





25th ANNIVERSARY!

The world's finest
precision disc
recording machine —
used and recommended
wherever the finest
recordings are made

Today — Write, Phone, or Wire
your order for
SCULLY MASTER RECORDERS

SCULLY Machine Company

62 Walter Street

Bridgeport 8, Conn.

Telephone BRidgeport 4-5300

THE BROADCAST ENGINEERS' JOURNAL

Ed. Stolzenberger Editor and
Business Mgr.

Editorial, Advertising and Circulation Offices:
116-03 91st Avenue, Richmond Hill 18, N. Y.
Telephone: Virginia 9-5553

Volume 14, No. 2



February, 1947

Contents Copyright, 1947, by NABET Publications

TABLE OF CONTENTS

	Page
NABET Activity	3
1947 I.R.C. National Convention	4
Photoelectricity	8
Submarine Stalker Now Seeks Oil	12
Television Control Equipment	14
Towers Tumble	18
West of "You-know-where"	18
Gene "Dynamike" Clark of WOR	20
Ed Horstman — The Poor Man's Frank Buck!	22
Baltimore News	23
San Francisco BC-375-E News	24

THE BROADCAST ENGINEERS' JOURNAL

OFFICIAL PUBLICATION OF THE N.A.B.E.T.

Trustees: A. T. POWLEY, Chairman; C. L. BENNIS, R. R. DAVIS,
M. JACOBSON, W. L. PAYNE, G. RILEY

Treasurer..... H. E. HILLER

ASSOCIATE EDITORS

Baltimore.....	ALEC BEAUCHAMP
Boston.....	JAMES W. HUGHES
Chicago.....	D. R. FITCH
Cleveland.....	EARL HOLL
Denver.....	GEORGE POGUE
Detroit.....	DAVE STEWART
Dixie.....	D. GORDON MCCRARY
Engineering Chap.er.....	E. B. BERLUND, JACK IRVING
Hollywood.....	NORMAN DEWES
Hudson Chapter.....	PAT MILLER
Mohawk.....	J. W. GAGNE
New York.....	GIL McDONALD
Omaha.....	CY HAGRMAN
Philadelphia.....	
Pittsburgh.....	FRANK E. HENRY
Rochester, N. Y.....	GEORGE WILSON, DONALD ANDERSON
San Francisco.....	KEN MARTIN, JACK VAN WART
St. Lawrence, N. Y.....	MISS ALEEN CORBIN
Washington.....	L. A. MCCLELLAND

The Broadcast Engineers' Journal is a privately printed monthly publication issued by NABET Publications. Address all communications to Publication office: E. Stolzenberger, 116-03 91st Avenue, Richmond Hill 18, L. I., N. Y. Telephone Virginia 9-5553.

Advertising rates and information supplied on request. Subscription, \$2.50 per year; \$4.00 for two years. Single copies, except Christmas Yearbook, 35c; Christmas Yearbook, \$1.00. All remittances in advance. Foreign: add postage. Back copies 50c, back Yearbooks, \$2.00.

Nothing appearing in The Broadcast Engineers' Journal shall be construed to be an expression of The Broadcast Engineers' Journal or the National Association of Broadcast Engineers and Technicians, but must be construed as an individual expression of the author or authors.

NATIONAL N.A.B.E.T. OFFICE
Room 501, 66 Court Street, Brooklyn 2, N. Y.
A. T. Powley, President

NABET ACTIVITY

FLASH . . . With network negotiations for the major chains about to begin. New York negotiators representing NABET and IBCW thought it desirable to get together and discuss contract problems and new proposals. Toward that end, a joint meeting was held on Friday evening, January 17th, at the Lexington Hotel, New York City. During the meeting, national and local problems were explored and all forms of contracts discussed. It was further decided that when the out-of-town negotiators reached New York, that another joint meeting should be held and that both unions should keep in close touch with each other during the forthcoming network negotiations.

. . . Representing NABET was A. T. Powley, Harry Hiller, and Cliff Gorsuch, National Office; Walter Payne, WOR, and Charles Bennis, NBC-ABCo. Present for IBCW were Charles Calame, business manager for IBCW Local 1212, and Harold Katan, assistant business manager for IBCW Local 1212, and Arthur Moore, WMCA.

Hollywood Office News Letter

Here is a copy of the proposed constitution of the "Council of Radio Arts and Crafts." This council was formed in Hollywood in August, 1946, primarily to provide a means of exchanging information between the radio unions in the Southern California area.

The first organization of this type was formed in San Francisco in March, 1946, and is called the "Northern California Inter-Union Radio Council." NABET is a member of this group and is represented on the Council by Mr. McDonnell, San Francisco Chapter Chairman. The form and pattern of the Southern California council followed very closely that of the San Francisco organization.

The unions participating in the "Council of Radio Arts and Crafts (CRAC) are:

- Radio Writers Guild (Ind)
- Radio Directors Guild (AFL)
- International Brotherhood of Electrical Workers, Local 40 (AFL)
- Office Employees International Union (AFL)
- American Federation of Musicians (AFL)
- American Federation of Radio Artists (AFL)
- Screen Publicists Guild (AFL)
- National Association of Broadcast Engineers and Technicians (Ind)

To date, 3 of these organizations have ratified the proposed constitution, RWG, RDG, and NABET.

There has been considerable discussion concerning the formation of a national organization of councils to perform the same functions nationally that the present councils perform on a regional basis. It would seem to be a worthwhile effort, inasmuch as there is no binding commitment to action on the part of any participating union and there is much to be gained from a discussion of common problems and strategy and as a means of exchanging information. In the meantime, the formation of local councils such as the San Francisco and Hollywood councils is of value to those cities where a number of radio unions are active.

Current activity at Hollywood centers around: 1. The Air Conditioning contract negotiations which have just been completed for the NBC Hollywood air conditioning staff; and 2. The organization of the Salt Lake City area. More information on these matters will be given you by the National Office when completed.

Proposed Constitution

Council of Radio Arts and Crafts

FOREWORD: Inasmuch as full cooperation, the free exchange of ideas and the discussion of common problems is deemed beneficial to the various collective bargaining organizations in the Los Angeles region radio industry, we, the collective bargaining agencies representing employees in the Los Angeles region of the radio industry, agree:

PARAGRAPH ONE: That the furtherance of full cooperation,

(Continued on Page Fifteen)

National Association of Broadcast Engineers and Technicians

The only Union that is 100% Of, By and For the
BROADCAST ENGINEER

Attention Broadcast Engineers!

- NABET is a dignified union worthy of your support.
- NABET is an effective union, Of, By, and For the Broadcast Engineer exclusively, operated upon and dedicated to the principle that every member has a right to know what is going on in the union's "front office."
- NABET is controlled by its members; they have the right to vote on all matters of union policy. As a NABET member, you would have the right to Okay any actions which your President might take.

Contact any of the following officers for further information

- | | |
|---|--|
| A. T. Powley, President | John H. Hogan
9312 Sudbury Road
Silver Springs, Md. |
| Harry C. Hiller
Nat'l Sec'y-Treasurer
66 Court Street
Brooklyn 2, N. Y. | William Justin Flanders
2 Holly Street
Hingham, Mass. |
| James H. Brown
Vice President
6000 Sunset Boulevard
Hollywood 28, Calif. | Wm. H. Johnson
100 E. Manda Road
Havertown, Pa. |
| C. A. Allen
National Representative
1240 N. Utah
Arlington, Va. | C. Edward Jung
1405 Carswell Street
Baltimore 18, Md. |
| Charles L. Bennis
Apt. DA-2
117-14 Union Turnpike
Kew Gardens 15, N. Y. | John R. McDonnell
252 Oakdale Avenue
Mill Valley, Calif. |
| Harold V. Brandt
19 Elm Street
Brecksville, O. | Mark L. McGowan
2703 Spalding Street
Omaha, Neb. |
| Reid R. Davis
18 Squirrel Hill Road
Roslyn Heights, N. Y. | Don Morey
Apt. 26-A, 3 Circle Lane
Albany 3, N. Y. |
| J. Willard Dean
217 E. North Street
Raleigh, N. C. | Donald A. Muir
1200 W. Colvin Street
Syracuse 7, N. Y. |
| Garland S. Dutton
1225 Clarkson Street
Denver, Col. | Walter L. Payne
68-07 Colonial Avenue
Forest Hills, N. Y. |
| Roger C. Ellis
820 University Place
Grosse Pointe, Mich. | Clyde M. Reed
363 Olancho Avenue
Brentwood, Pgh., Pa. |
| George Gebhard
134 William Street
Watertown, N. Y. | Frank C. Schnepfer
3508 West 97th Street
Evergreen Park, Ill. |
| | Charles Synder
106 Pembroke Street
Rochester 7, N. Y. |

1947 I. R. E. National Convention

March 3rd to 6th, (inclusive), Hotel Commodore and Grand Central Palace, New York

By Ed. Stolzenberger

THE Institute of Radio Engineers will hold its annual "latest-in-electronic developments" Convention, March 3-6 inclusive. It promises to be one of the most consequential meetings in the history of the I.R.E.! Over 150 manufacturers are slated to exhibit the most recent fruits of radio and electronic research at New York's Grand central Palace over the four-day period. For non-members as well as members of the Institute, there will be the reading of 120 highly technical papers of vital consequence to the most recent developments in radio and electronic engineering.

Dr. R. W. G. Baker, vice president of the G.E. Co., has recently been elected president of the IRE. Dr. Baker is additionally Director of the Engineering Dept of the RMA; member of the Board of Governors of the Nat'l Electrical M'fgrs Ass'n; and Chairman of the Electronics Committee of the AIEE. He had previously been Chairman of the N'tl Television Systems Committee of the television industry, and was the first Chairman of the electronics industry's Radio Technical Planning Board.

List of Technical Papers

Monday Afternoon, March 3, 1947

Particle Accelerators for Nuclear Studies

Chairman: J. R. Zacharias

- "Particle Accelerators for Nuclear Studies"—C. W. Dunlap
- "FM Cyclotron"—W. Salisbury
- "The Betatron"—T. M. Dickinson
- "A 70 MEV Synchrotron"—A. M. Gurewitsch, H. C. Pollock, R. V. Langmuir, F. R. Elder, J. P. Blewett
- "The Linear Accelerator"—J. C. Slater

Electronic Measuring Equipment

Chairman: J. E. Brown

- "A Method of Determining and Monitoring Power and Impedance at High Frequencies"—J. F. Morrison and E. L. Younker.
- "Theory of Measurement of Dielectric Properties at 10,000 Mc/sec."—C. V. Larrick
- "A Coaxial-Line Noise Source for Ultra-High Frequency"—H. Johnson
- "A New Reactance-Tube Distortion and Noise Meter"—C. W. Clapp
- "Cathode Ray Presentation of Three-Dimensional Data"—O. H. Schmitt

Radar and Communication Systems

Chairman: E. M. Deloraine

- "Shipboard Radar Fire Control from the System Viewpoint"—Robert M. Page and John B. Trevor, Jr.
- "System Considerations in the Design of VHF and SHF Communication Circuits"—E. Fubini
- "Portable Military Communication Set"—C. E. Sharp
- "Carrier Current Dialing Over Long Distance Telephone Circuits"—I. Molnar
- "Cesium Vapor Lamps in Infrared Communication"—M. C. Beese

FM Reception

Chairman: M. G. Crosby

- "FM Detector Systems"—B. D. Loughlin
- "Broadband FM Detector for Multi-Channel Communication"—J. W. Albersheim
- "Method for Measurement of Instantaneous Frequency of an FM Oscillator"—L. E. Hunt
- "A Variable Phase Shift Frequency Modulated Oscillator"—O. E. DeLange
- "Linearity in Tuned Transformer Frequency Discriminator"—H. R. Summerhayes, Jr.

I.R.E. Winter Convention — Schedule of Technical Program

Room Seating Cap.	HOTEL COMMODORE			GRAND CENTRAL PALACE	
	East Ballroom (500)	Main Ballroom (2000)	West Ballroom (400)	Auditorium I (450)	Auditorium II (450)
MONDAY, MARCH 3 Afternoon 2-5 PM		Particle Accelerators for Nuclear Studies	Electronic Meas. Equipment	Radar & Commun. Systems	FM Reception
TUESDAY, MARCH 4 Morning 10A-12:30 PM	Aids to Navigation		Nucleonics Instrumentation	Microwave Components & Test Equipment	Television A
Afternoon 2:30-5 PM	Television B		Electronic Digital Computers	Power Output Vacuum Tubes	Circuit Theory
WEDNESDAY MARCH 5 Morning 10A-12:30 PM	Electronic Controls & Applications	Aids to Air Nav. & Traffic Control		Microwave Tech. and Meas.	Broadcasting & Recording
Afternoon 2:30-5 PM		On the Prof. Status of the Engineer			
THURSDAY, MARCH 6 Morning 10A-12:30 PM	Oscillator Circuit Theory		Basic Electronics Research	Wave Propagation and Antennas	Relay and Pulse-Time Systems of Communication
Afternoon 2:30-5 PM	Receiver Circuits		Vacuum Tubes and Gas Rectifiers	Antennas	Wave Guide Techniques

Tuesday Morning, March 4, 1947

Aids to Navigation

Chairman: W. L. Barrow

- "Relations Between Bandwidth, Speed of Indication, and Signal-to-Noise Ratio in Radio, Navigation and Direction Finding"—H. Busignies and M. Dishal
- "Targets for Microwave Radar Navigation"—S. D. Robertson
- "A Comparison of Interrogation By Search Radars and By Separate Interrogators in Pulse Transponder Systems"—F. A. Darwin
- "Low Frequency Loran"—V. S. Carson, S. Seton, M. Rothman, M. Pomerantz
- "Elimination of Precipitation Static"—W. H. Bennett

Nucleonics Instrumentation

Chairman: W. C. White

- "Nucleonics Instrumentation"—V. C. Wilson
- "Proportional Counters and Geiger Counters"—S. Korff
- "Cloud Chambers"—G. C. Baldwin
- "Applications of the Vibrating Reed Electrometer"—W. P. Jesse
- "Counters and Pulse Amplifiers"—M. Sands

Microwave Components and Test Equipment

Chairman: W. H. Doherty

- "Experimental Determination of Helical Wave Properties"—C. C. Cutler
- "A Stabilized Magnetron for Beacon Service"—C. P. Vogel, J. S. Donal, Jr., B. B. Brown, C. L. Cuccia, W. J. Dodds
- "Coupled Circuits Used As Tunable Band-Pass Filters in the Ultra-High-Frequency and Microwave Region"—R. O. Petrich
- "Broad-Band Ultra-High-Frequency Amplifiers"—A. M. Levine and M. G. Hollobaugh
- "The Measurement of Delay Distortion in Microwave Repeaters"—D. H. Ring

Television A

Chairman: D. B. Sinclair

- "Synchro-lite for Television Film Projectors"—L. C. Downes and J. F. Wiggin
- "Video-Frequency Negative-Feedback Amplifiers"—M. G. Hollobaugh and A. M. Levine
- "Radio Frequency Performance of Some Receiving Tubes for Television"—R. Cohen
- "Theory of Multi-Stage Wide-Band Amplifier Design"—W. E. Bradley
- "Recent Advances in the Design of Intermediate Frequency Amplifiers for Television Receivers"—C. Marsh

Tuesday Afternoon, March 4, 1947

Television B

Chairman: E. W. Engstrom

- "Cathode Ray Tubes and Optical Systems"—H. Rinia, J. de Gier, P. M. Van Alphen
- "High Voltage Unit and Deflection Circuit"—J. Haantzes, G. J. Siezen and F. Kerkhof
- "Cathode-Ray Flying-Spot Scanner for Television Signal Generation"—R. D. Kell and G. C. Sziklai
- "Gas-Discharge-Tube Television Deflection Systems"—K. R. Wendt
- "An Improved Counter-Time for Television"—C. E. Hallmark

Electronic Digital Computers

Chairman: H. Diamond

- "The Electronic Digital Computers"—J. W. Forrester
- "Input Mechanisms for Electronic Digital Computers"—S. N. Alexander
- "Electronic Computing"—H. H. Goldstine
- "A Tube for Selective Electrostatic Storage"—J. A. Rajchman
- "Applications of Electronic Digital Computers"—P. Crawford

Power Output Vacuum Tubes

Chairman: L. Malter

- "Screen Grid Transmitting Amplifier Tubes for Operation Up To 500 Mc/sec."—W. G. Wagener

"A New FM and Television Power Amplifier Tube and Its Associated Grounded Grid Cavity Circuit"—H. D. Wells and R. I. Reed

"Frequency Modulation and Control by Electron Beams"—L. P. Smith and C. Shulman

"A Frequency-Modulated Magnetron for Super-High Frequencies"—G. R. Kilgore, C. Shulman, J. Kurshon

"A One-Kilowatt Frequency-Modulated Magnetron for 900 MC/sec."—J. S. Donal, Jr., R. R. Bush, C. L. Cuccia, H. R. Hegbar

"New Technique in Glass to Metal Sealing"—J. A. Pask

"Determination of the Mutual Heating of Helical Filaments"—M. Youdin

Circuit Theory

Chairman: H. A. Wheeler

"Phase and Amplitude Distortion in Linear Networks"—M. J. DiToro

"Correlation of Network Frequency Response and Square Wave Shape"—R. Lee

"Compensation of Phase Shift at Low Frequencies"—F. McGee

"Parabolic Loci of Coupled Circuits"—S. H. Chang

"Reciprocity Failure in Crystal Networks"—L. Apker, E. Taft and J. Dickey

Wednesday Morning, March 5, 1947

Electronic Controls and Applications

Chairman: Virgil M. Graham

"Electronic Control in Industry"—G. M. Chute

"Variable Radio Frequency Follower System"—R. F. Wild

"Continuous Recording Sensitive Magnetometer"—R. F. Simmons

"Three Dimensional Representation on Cathode-Ray Tubes"—C. Berkley

"New Electronic Wiring Techniques"—C. Brunetti

Aids to Air Navigation and Traffic Control

Chairman: A. F. Van Dyke

"The Function of Air Traffic Control"—W. White

"Trends in Air Navigation"—H. Davis

"Hazeltime Lanac System (Laminar Air Navigation Anti-Collision)"—K. Mellwain

"First Tests on Navar System for Aerial Navigation and Air-Traffic Control"—H. Busignies and P. R. Adams

"The Application of Microwaves to the Guidance and Control of Aircraft"—J. Lyman and G. Litchford

Microwaves Techniques and Measurements

Chairman: E. Bown

"Precision Measurements of Impedance Mismatches In Wave Guide"—A. F. Pomeroy

"A Coaxial Line Support for 0-4000 mc."—R. W. Cornes

"Power Leads At Very and Ultra High Frequencies"—A. G. Kandoian and R. A. Felsenheld

"Direct Reading Wavemeters"—G. E. Feiker and H. R. Meahl

"The Operational Behavior of a Magnetron Microwave Generator When Coupled to a Long Transmission"—W. C. Brown

Broadcasting and Recording

Chairman: R. F. Guy

"Propagation Characteristic of the UHF (480-920 Mc.) Television Band"—W. B. Lodge

"Theoretical and Practical Aspects of FM Broadcast Antenna Design"—P. H. Smith

"Monitoring Equipment for FM Broadcasting"—M. Silver

"Ultra-High-Frequency Multiplex Broadcasting System"—A. G. Kandoian and A. M. Levine

"Field Measurements on Magnetic Recording Heads"—D. L. Clark and L. L. Merrill

Wednesday Afternoon, March 5, 1947

Special Session—"The Engineering Profession"

Thursday Morning, March 6, 1947

Oscillator Circuit Theory

Chairman: H. M. Turner

- "Limitations of the Superregenerative Circuit"—H. Stockman
- "Theory of Amplitude Stabilized Oscillators"—P. R. Aigrain and E. M. Williams
- "Synchronization of Oscillators"—R. D. Huntoon and A. Weiss
- "Operating Characteristics of Coupled-Circuit Oscillators"—D. K. Cheng

Basic Electronic Research

Chairman: F. B. Llewellyn

- "The Electronic Research Sponsored by the Office of Naval Research"—E. R. Piore
- "Spherical Aberration of Compound Magnetic Lenses"—L. Marton and K. Bol
- "Field Emission Arc As An Electron Source"—C. M. Slack and D. C. Dickson
- "Response of a Thermionic Vacuum Tube to the Sudden Application of an External Voltage"—E. H. Gamble
- "Noise-Suppression Characteristics of Pulse Modulation"—S. Moskowitz and D. D. Grieg

Wave Propagation and Antennas

Chairman: H. R. Skifter

- "A Study of Tropospheric Reception at 42.8 Mc. and Meteorological Conditions"—G. W. Pickard and H. T. Stetson
- "Results of Microwave Propagation Tests on a 40-Mile Overland Path"—A. L. Durkee
- "A Method of Rapid Continuous Measurement of Antenna Impedance Over a Wide Frequency Range"—H. V. Cottony
- "A Phase-Front Plotter for Centimeter Waves"—H. Iams
- "Aircraft Antenna Pattern Measuring System"—O. H. Schmitt

Relay and Pulse Time Systems of Communication

Chairman: W. O. Swinyard

- "Consideration of Noon Relay Communications"—H. Rusignies and D. D. Grieg
- "Experimental Studies of a Remodulating Repeater System"—W. M. Goodall
- "Experiences with Multipath Transmission at VHF, UHF, and SHF"—F. P. Morf
- "Multiplex Employing Pulse Time and Pulsed FM Modulation"—H. Goldberg and C. C. Bath
- "Multiplex Microwave Radio Applied to Telephone Systems"—T. H. Clark

Thursday Afternoon, March 6, 1947

Receiver Circuits

Chairman: E. L. Chaffee

- "Synchronous Detectors"—J. G. Reid, Jr.
- "A Wide Band 550-Megacycle Amplifier"—R. O. Petrich
- "A Compact Electro-Mechanical Filter for the 455 Kc. I. F. Channel"—R. Adler
- "Receiver Sensitivity at the Higher Frequencies"—J. M. Pettit

Vacuum Tubes and Gas Rectifiers

Chairman: J. Slepian

- "Beam-Deflection Control for Amplifiers and Mixers"
 - "High Transconductance Design Considerations"—G. R. Kilgore
 - "Mixer Tubes for Ultra-High Frequency"—E. W. Herold, C. W. Mueller, H. A. Finke
- "A New 100-Watt Triode for 1000 Megacycles"—W. R. Keye, C. E. Haller, E. A. Eschbach, W. P. Bennett
- "A Study of Microphonics in a Sub-Miniature Triode"—V. W. Cohen and A. Bloom
- "Design of Gas-Filled Cold-Cathode Tubes"—G. C. Rich
- "Recent Advances in High Voltage Rectifiers for Television Receivers"—G. Baker

Antennas

Chairman: C. R. Burrows

- "Fundamental Limitations of Small Antennas"—H. A. Wheeler
- "Helical Antenna for Circular Polarization"—H. A. Wheeler
- "The Directly-Fed Vertical Stabilizer as a Zero-Drag Broad-Band Aircraft Antenna for HF and VHF"—R. S. Wehner
- "Antennas for Modern Transport Aircraft"—R. S. Wehner
- "A Study of Networks Useful in Broad-Banding and Diplexing Turnstile Antennas for Television Transmission"—G. H. Brown, J. Epstein, D. W. Peterson and O. M. Woodward, Jr.
- "Radiation Patterns of Thick End-Fed Antennas"—C. H. Page, R. D. Huntoon and P. R. Karr
- "A New Type of Broad-Band Zero-Drag Aircraft Antenna"—A. Dorne and J. Margolin
- "Circularly Polarized Antennas"—W. Sichak and S. Milazzo

Wave Guide Techniques

Chairman: I. Wolff

- "An Adjustable Wave Guide Phase Changer"—A. G. Fox
- "Developments in Broadbanding of Microwave Plumbing Components"—J. H. Vogelmann
- "A Consideration of Directivity in Wave Guide Directional Couplers"—S. Rosen and J. T. Bangert
- "Electrical Measurements on Transmission Cavity Resonators at 3 cm. Wavelength"—M. S. Wheeler
- "Design of a Resonant Cavity for Frequency Reference in the 3 cm. Range"—R. R. Reed

Radio Engineering Show Hours

Grand Central Palace, 46th Street and Lexington Avenue, New York City

Monday, March 3, 12 M. to 9 P.M.

Tuesday, March 4, 12 M. to 9 P.M.

Wednesday, March 5, 10 A.M. to 6 P.M.

Thursday, March 6, 12 M. to 9 P.M.

Social Calendar

"Get-together" Cocktail Party

Monday, March 3, 6-8 P.M. at The Hotel Commodore

President's Luncheon

Tuesday, March 4, 12:45 P.M. at The Hotel Commodore

I.R.E. Annual Banquet

Wednesday, March 5, 7 P.M. at The Hotel Commodore

Available for Employment

- (Contact the NABET National Office for any further information)
- W. A. ERICKSON, several years broadcast experience—ABC, KFI. Mixer and maintenance.
 - BENNETT W. WHITE, 11 years Fox studio camera and sound dept—6 months mixer KFI. 2nd class phone.
 - MERLE B. PETERSON, 4 years regional station experience. 1 year ABC mixer, 4 years US Navy Ch. Radio Electrician. 1st class phone, 2nd class telegraph.
 - JOHN B. MCLEOD, radio service 5 years. 2 years recording engineer. 1 year regional station engineer. 6 months NBC recording engineer.
 - CHARLES L. COOK, 6 years organist, 2 years KFI mixing and recording. 1½ years ABC studio-field engineer. Telephone 1st.
 - CECIL C. CAVES, 6 years local and regional station engineer and chief engineer, 3 years U. S. Navy airborne radar installation, 6 months KFI mixer and maintenance.
 - WALLY C. RIPPEL, 20 years total experience mixer, maintenance, control room. WHN, KFI, ABC, and NBC. Telephone 1st.
 - B. LeROY WOLFE, 4 years broadcast, 1½ years Westinghouse navy radar. KYW 1 year, FCC 6 months. Telephone 1st, telegraph 2nd.
 - HARRY B. BEKKAR, 3 years Army radar development and operation, 12 years amateur radio. NBC Hollywood vacation relief maintenance engineer.
 - C. LOWELL FRANK, 11 years mixer and recording, WOR 5 years, Western Electric 2 years.

change pitch and direction almost
instantaneously with the improved
Presto 8-D Recorder

The Improved Presto 8-D Recorder is equipped with a reversing device for the feed screw. Result: Six feed pitches, inside-out *and* outside-in, using only one feed screw. This feed screw need never be removed from the recorder. Thus, changes in pitch and direction are accomplished within a matter of seconds.

The Presto 8-D Recorder is the easiest and most convenient machine to operate because of the arrangement of its controls and the cantilever overhead which saves lost motion in operation. Its unusually heavy construction assures high fidelity masters and instantaneous recordings.

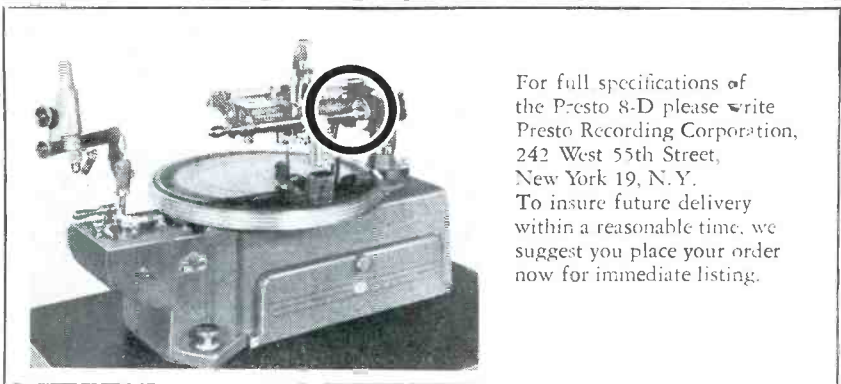
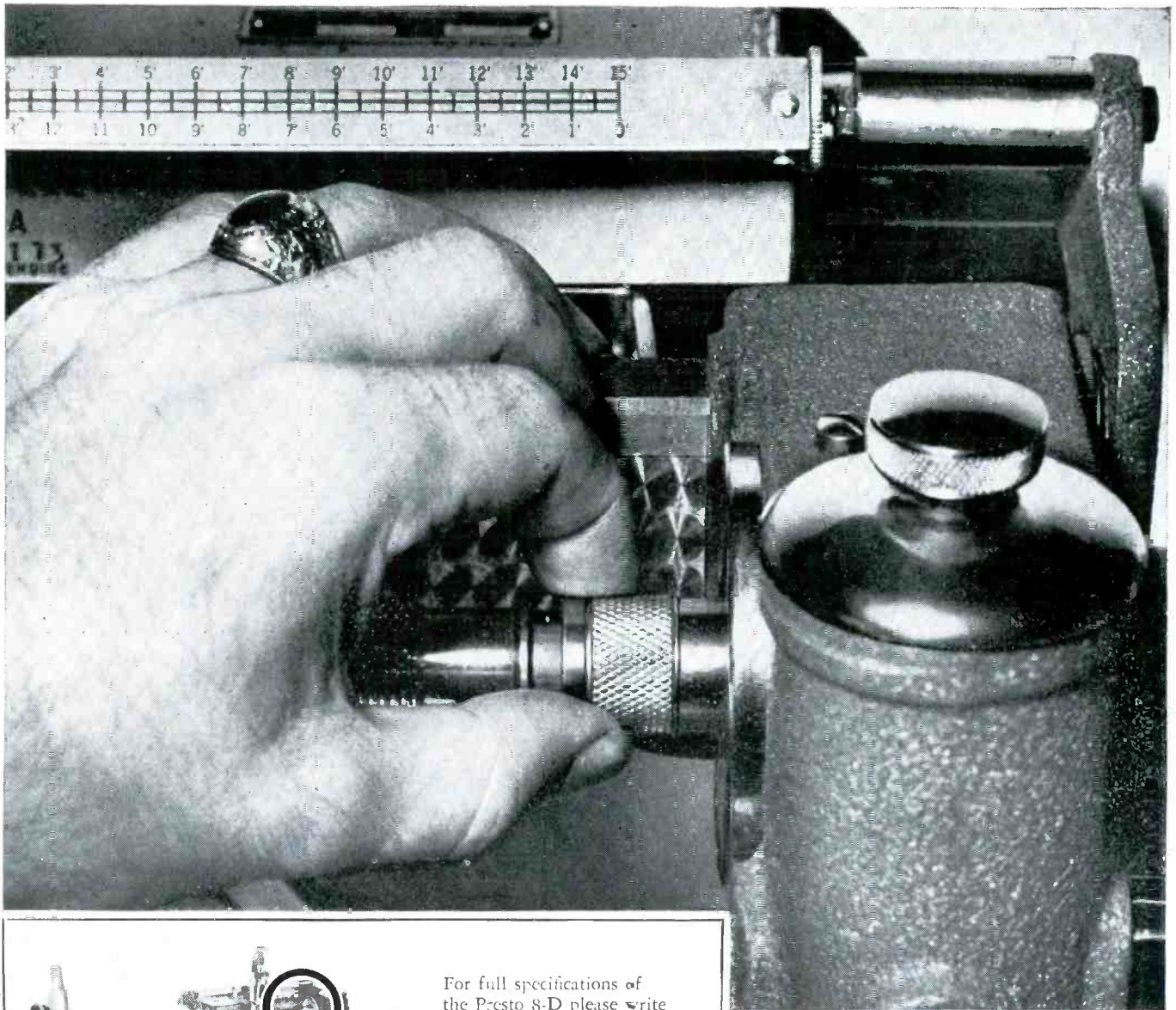

For full specifications of the Presto 8-D please write Presto Recording Corporation, 242 West 55th Street, New York 19, N. Y. To insure future delivery within a reasonable time, we suggest you place your order now for immediate listing.

PRESTO

RECORDING CORPORATION
242 West 55th Street, New York 19, N. Y.
Walter P. Downs, Ltd., in Canada

World's Largest Manufacturer of Instantaneous Sound Recording Equipment

Photoelectricity

By Jordan McQuay

Principles and Practice of Photoelectric Phenomena: Photoemission, Photoconduction, Phototubes and Cells

FAR above the operating frequencies of radio, television, and radar are the light waves of color—electromagnetic radiations of extremely high frequency that can actually be seen (detected) by the human eye.

Although the visible region occupies an extremely small segment of the entire range of electromagnetic radiations, as shown in figure 1, this narrow segment is of great importance in certain aspects of electronic control.

Fundamental principles on which are based the phenomena of photoelectric equipment design and operation are relatively simple of comprehension, once details of photoemission are understood. And with greater use of certain of these principles in television and industrial electronics, a knowledge of these aspects is essential for operations, engineering, and maintenance.

Light and Color

Light waves, like radio waves, have a characteristic frequency or wave length. But the lengths of light waves are very much shorter. They can be measured in centimeters, but it's more convenient to use a smaller unit called the *Angstrom*: equal to 10^{-8} centimeters.

Red light is about 8000 Angstroms, Violet light is about 4000 Angstroms. And these represent the practical limits of human vision. (See figure 1.)

Light waves of less than about 4000 A are so high in (comparative) frequency that they cannot be seen, and are known as *ultra violet light*. Red light of more than about 8000 A and which is so low in (comparative) frequency that it cannot be seen, is known as *infra red light*. Although invisible to the naked eye, both of these types of electromagnetic radiations have special uses. And the following principles apply equally to these "invisible" light waves, which are considered within the scope of photoelectric phenomena.

The conversion of light waves of all frequencies into electrical waves is known as the *photoelectric effect*. This is invariably accomplished by a procedure known as *photoelectric emission* using *phototubes*. But two other procedures—less popular, less-known, and employing *cells*—may be used for the conversion of light waves; these will be discussed later in this article.

Originally discovered in 1887 by Hertz, the *photoelectric effect* was later studied by Hallwachs, even later by Thomson. But it was not until 1905 when Einstein gave a satisfactory explanation of photoelectric phenomena, that the *effect* was understood and put to practical use. By photoelectric phenomena is meant the influence of light waves on some component of an electronic system.

Photoelectric Emission

Dislocation of electrons from molecules produces free electrons which, when allowed to move in a circuit, produce a state of charge. And thus "creates" electricity.

Ease of dislocation or separation of electrons depends upon the molecular construction of materials—particularly certain metals. And the process of liberation is known as *electron emission*.

This may be accomplished in one of three ways.

When the temperature of metallic bodies is raised sufficiently, free electrons are ejected and allowed to escape

from the surface tension of the metal. This is known as *thermionic emission*, and used commonly in almost all types of conventional electron tubes.

Electrons may also be given off by a metallic surface, when it's bombarded by electrons moving at a sufficiently high speed—usually originating from another source. This is called *secondary emission*, and likewise is encountered quite often in electronic circuits operating at comparatively low frequencies.

A third form of electron emission takes place when light waves are allowed to fall on certain metals. Alkaline earths—such as cesium, rubidium, and potassium—exhibit this phenomenon when irradiated with wave lengths within the visible spectrum of electro magnetic radiation. Electrons are emitted in proportion to the intensity as well as the frequency (color) of the impinging light. And this effect is known as *photoelectric emission*.

The emitting surface may be composed of one or more of a number of specific light-sensitive metals. Best emitters are the alkali metals and alkali earth metals. Listed in order of their desirability: cesium, rubidium, potassium, barium, sodium, strontium, lithium, and calcium.

Often a *film* of one of these metals is sprayed or placed on a surface composed of the oxide of the same metal which, in turn, is deposited upon a base metal. This method of composition produces an increase in the durability and sensitivity of the electron emitter.

Since the metals listed above are characteristically sensitive to slightly different portions of the visible spectrum, *combinations* may be used to improve the general frequency response or, in some cases, to emphasize certain color frequencies.

For example, a surface consisting of cesium, cesium-oxide, and silver is especially sensitive to bright red. It emits large quantities of electrons when subjected to red or infra-red light waves. Other combinations show marked sensitivity to higher frequency colors well into the ultra violet range.

The lowest frequency of light which causes emission is known as the *threshold frequency* of the metal surface.

Intensity and Color

The *amount* of electron emission is influenced by the metal content of the emitter and, to a slight extent, by the physical shape of the emitting surface.

Assuming these two conditions to be optimum, when a light impinges upon a photoelectrically sensitive surface, the following important relations exist:

(1) *The number of electrons released per unit time is directly proportional to the intensity of the light.*

(2) *The maximum energy of released electrons is entirely independent of the intensity of the light.*

(3) *The maximum energy of released electrons is approximately proportional to the frequency (color) of the light.*

These relationships are accurate over an extremely wide range of light intensity: from those less than the human eye can detect to direct sunlight. And the relationships are accurate for thick or thin coatings of photosensitive metals.

However, the relationship between color (frequency)

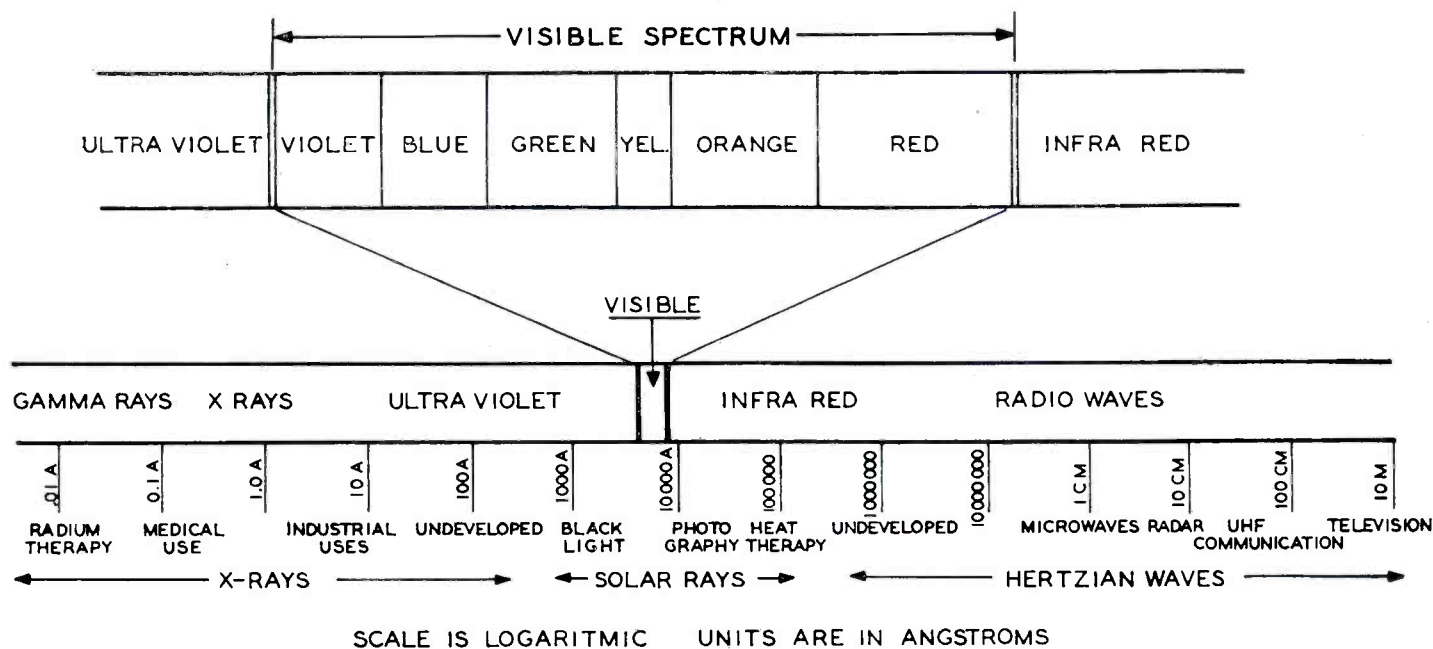

THE RANGE OF ELECTROMAGNETIC RADIATION

FIG. 1

and emission is subject to a somewhat variable factor often difficult to ascertain with any degree of accuracy, because different sources of light radiate different frequencies in different proportions.

For example: sunlight has almost constant intensity throughout the entire visible spectrum. But radiations from an ordinary light bulb have predominantly strong low frequencies (reddish colors) and greatly attenuated higher frequencies (bluish colors).

Also, some frequency discrimination is sometimes due to the metallic content as well as the physical shape of the photoelectric emitter.

If the strength of the incident light is maintained constant and its frequency (color) is varied, there is a decrease in electron emission as the color approaches ultra violet. And there is an increase in emission as the color approaches red and infra-red frequencies.

Ability of the emitter or cathode to favor certain frequencies and discriminate against others is known as *spectral selectivity*. And the *spectral response* expresses the relative amount of photoelectric current produced by light of different colors.

The true sensitivity of a cathode depends largely upon the frequency of the light impinging upon the metallic surface. But as an arbitrary basis for comparing different sensitivities, the industry has standardized on a tungsten-lamp source operated at 2870 degrees Kelvin.

[Absolute zero = -273° C = 0° Kelvin—Ed S.]

Photoelectric action is practically instantaneous. There is no significant time lapse between illumination of the cathode surface and the emission of electrons.

One characteristic limitation of this action should be noted, however. Even under optimum operating conditions, photoelectric emission is accomplished with poor efficiency.

The Basic Phototube

Electrons emitted by the light-sensitive surface of the cathode are collected by a plate or anode. The second electrode is simple in structure: either a straight wire equispaced from and partially surrounded by the cathode (figure 2), or a ring structure supported in such a way as not to obstruct the cathode.

When a positive potential is applied to the anode, the negatively charged electrons are attracted to the anode.

And the passage of electrons from cathode to anode provides current conduction.

However, no linear relationship between light intensity and current flow will be possible, unless the arrangement of two electrodes (figure 2) is enclosed within a typical glass envelope. Result is a high vacuum tube, from which all gas has been exhausted. Otherwise the presence of "stray" gas molecules would exert considerable influence on the passage of electrons from cathode to anode.

The appearance and circuit action of the resultant device somewhat resembles an ordinary diode.

It is commonly known as a *phototube*, sometimes called a photoelectric tube or a photoelectric cell.

In the practical construction of a basic phototube, the alkaline substance is sprayed on the inner surface of a half-cylinder cathode (figure 2). And the anode consists of a small metallic rod placed lengthwise and with its center of radius conforming to that of the half-cylinder emitter.

Thermal heating of the cathode is not necessary. Because emission depends entirely upon the nature of the incident light.

Thus the phototube is known as a *cold cathode* electronic device. It makes possible the use of emitting substances which possess a high vapor pressure, and more stable films of photosensitive metals can be used on the cathode.

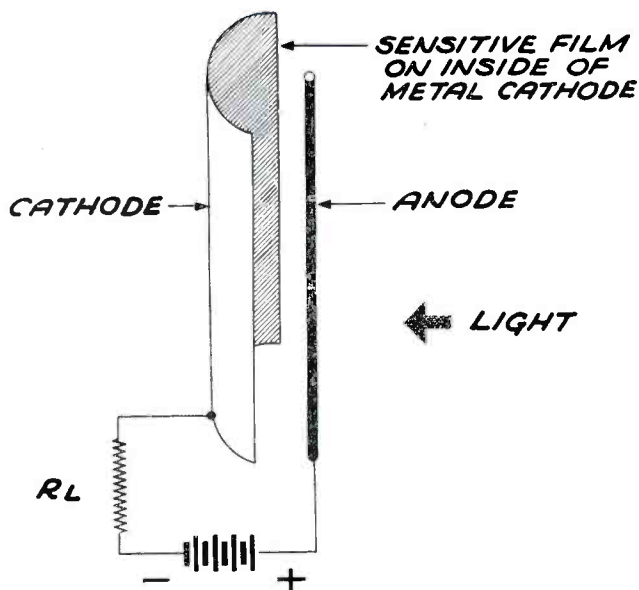

FIG. 2
BASIC PHOTOCELL

Conduction follows the $3/2$ -power law: current between anode and cathode increases as the $3/2$ power of the applied voltage regardless of the separation or shape of the two electrodes.

But current conduction takes place only when the cathode is illuminated by light waves of proper frequency (color) and intensity to cause electron emission.

The cathode may be illuminated from any direction that is possible physically. This is usually accomplished through the side of the half-cylinder left open. But other arrangements are feasible, if the intensity of the impinging light remains sufficient for normal operation of the phototube.

Light waves will generally pass through clear glass with attenuation, refraction, or distortion. However, sometimes the glass envelope is purposely coated to provide shadow-shielding or extreme directivity with respect to the incident light.

Since the magnitude of current conduction is extremely small in a phototube, every structural effort is made to minimize leakage currents (of the same order) within the tube. One method is to bring out one terminal at the top of the glass envelop, using the glass itself as an insulator between anode and cathode. As an additional precaution, the surface of the glass envelope can be coated with wax to exclude moisture.

The Gas-filled Tube

Similar in almost every respect to the basic phototube just described is the gaseous phototube, where a small quantity of argon gas is purposely introduced to provide greater output current. This also influences the relation between light intensity and current flow, due to the effect of ionization on the space charge.

While operation of the gaseous phototube is generally similar to operation of the same tube pumped free of gas, current flow is greater for a gas-filled tube.

Principle effect of introducing gas is to obtain greater cathode emission than the incident light might be capable of extracting. During ionization, ions congregate near the cathode and bombard the emitter. This condition is con-

ducive to secondary emission, and additional current from this source is of considerable magnitude.

As the intensity of the impinging light is increased, the degree of ionization also increases. However, if the light intensity continues to increase, the amount of ionization may reach the point of regeneration, and a self-sustained discharge will commence. For this reason, gas-filled phototubes must be adequately protected from both excessive light intensities and excessive operating voltages.

Most gas-filled phototubes use a cathode surface of cesium oxide, and the tubes are characteristically sensitive to red and infra red light waves.

Amplification

The output current for all types of phototubes is of very small magnitude, imposing a severe limitation on their circuit use. The only electronic apparatus that even a gas-filled (high output) phototube will operate directly is a sensitive galvanometer.

Thus amplification of the output of all types of phototubes is considered an absolute necessity.

Since the phototube output is a current and since conventional thermionic amplifiers require a voltage input, a high resistance in the input stage of the amplifier is necessary in order to produce a voltage drop of sufficient magnitude to operate the amplifying stage.

Except for this one (input) characteristic, phototube amplifiers use conventional circuits.

Typical a-c operated arrangement (figure 3) consists of phototube, amplifier tube, light source, and power supply. When the illumination from a conventional 70-watt 120 volt light bulb falls on the cathode of a type 868 gas-filled phototube, electrons are emitted and conduction takes place. Output current fluctuations are amplified by a gas-filled tetrode, type 2051, which supplies sufficient power to operate

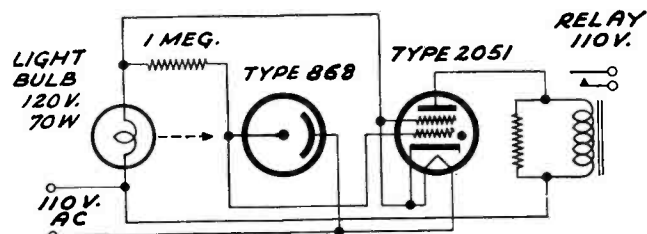

FIG. 3
TYPICAL A-C PHOTOTUBE CIRCUIT

a relay directly. The light bulb also serves to lower the A.C. input voltage to a value suitable for operating the filament of the amplifier tube.

The type 868 phototube (used above) is sensitive to visible and infra red light waves, but is only one of several popular types.

Tube Types

Types 917 and 919 are high-vacuum phototubes. Both have light response characteristics favorable to visible and infra red light waves.

Type 918 is a gas-filled phototube, similar to the 868 but possessing greater sensitivity to visible and infra red light waves.

Type 920 is a gas-filled phototube containing two complete photoelectric units, which can be operated independently of each other. Similar to the "double diode," the

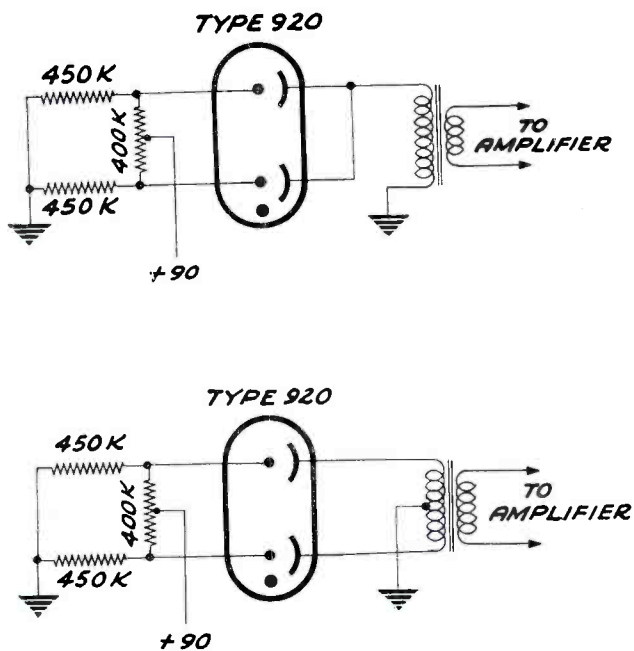

FIG. 4
CONVENTIONAL AND PUSH-PULL
ARRANGEMENTS OF TYPE 920 PHOTOCELL

glass envelope contains two cathodes and two anodes. Sometimes referred to as the *Twin Phototube*, it is widely used in the pick-up unit of motion picture projectors for sound-on-film reproduction. Two typical circuits are shown in figure 4. When used for conventional single-track reproduction, the cathodes are connected in parallel. For push-pull reproduction, the two cathodes are separated and operate alternately. The balancing potentiometer (figure 4) is adjusted to obtain minimum reproduction of the recorded sound at high volume.

Types 921, 922, and 926 are small cartridge-type phototubes about one inch in diameter and two inches in length. Type 921 is gas-filled, and has extremely high sensitivity to red and infra-red light waves. Types 922 and 926 are high-vacuum types with considerably less sensitivity by comparison.

Type 924 is a gas-filled phototube especially designed for relay service. Physically it resembles a small neon bulb, and is mounted in a small screw-type socket. Sensitivity is comparatively low, except for red light waves.

Types 928 and 930 are essentially nondirectional. They are both gas-filled, and have a cylindrical mesh cathode. They are highly sensitive to red and infra red light waves.

Type 929 is a high-vacuum phototube, which is sensitive to blue and ultra violet light waves.

The following high-vacuum phototubes are also sensitive to ultra violet light waves, but have extremely low output current: types FJ-76, WL-770, WL-773, WL-774, and WL-767.

Multipliers

An important variation of the basic two-electrode phototube is known as the *multiplier phototube*.

This is a high-vacuum electronic device which employs the principle of secondary emission to increase current amplification by means of a number of reflecting plates or *dynodes* within the photoelectric tube. Electrons initially released

from the surface of the cathode (in the usual manner) strike the first dynode, dislodging three or four electrons for each electron arriving from the cathode. These secondary electrons then are attracted to the next dynode where, on striking its surface, three or four electrons are dislodged by each electron impinging the surface. And this multiplication process continues, until an extremely large number of electrons are collected on the final dynode or anode. As many as eight, nine, or ten dynodes can be used—each (except the final) functioning as a secondary emitter of electrons. Output current is, in general, a linear function of the exciting illumination reaching the cathode of the multiplier.

Type 931 is typical of such a device, having nine dynatron stages. The cathode of this phototube is initially sensitive to blue, violet, and ultra violet light waves.

The Iconoscope

Another variation of the basic phototube is a device widely used in television and known as the *iconoscope*.

The cathode of this tube (figure 5) consists of minute cesium-oxide coated silver particles deposited upon a sheet of mica with a metal base plate. In effect there has been thus produced a *mosaic* of countless tiny phototubes. Because each individual particle and the metal base plate constitutes a minute condenser, each provides a current varying in accordance with the nature of the light striking it. The intensity of the light is determined, in turn, by the nature of the image being televised. This image is focused on the mosaic by an external lens system (figure 5). The mosaic plate is placed in a high vacuum, and a common anode is employed. The anode is usually a silvered portion of the glass envelope.

When focused properly, the optical image releases electrons from the mosaic—thus charging the anode positively according to the intensity of light received.

In television practice, the optical image being televised is electronically examined in such a manner that the pick-

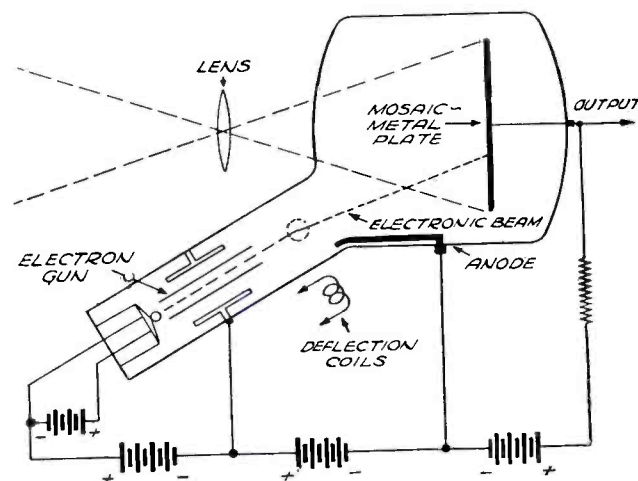
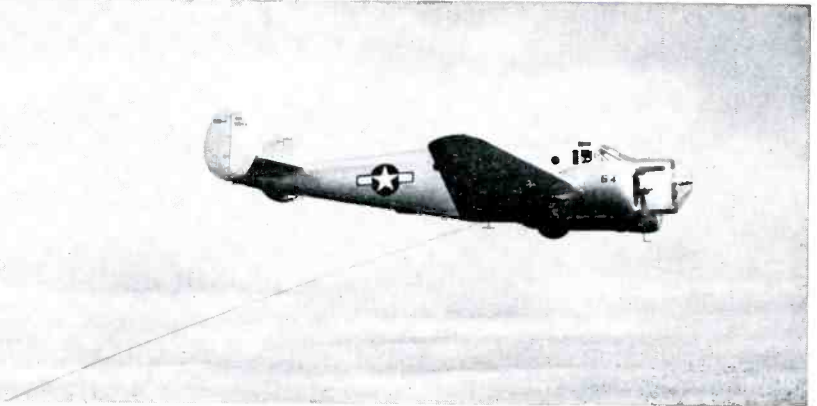

FIG. 5
THE ICONOSCOPE TUBE

up tube looks at individual points of mosaic illumination in time sequence. Thus, current variations are produced that correspond *successively* to the scanning of the picture elements contained in the subject being televised.

(Continued on Page Sixteen)



(Reprinted from the Bell Lab Record, July, 1946 issue—Ed S)

A REVOLUTIONARY device for aerial prospecting for potential oil and mineral-producing areas has been developed as an outgrowth of a hitherto secret means of magnetically finding and tracking submerged enemy submarines.

In its wartime role, the magnetic airborne detector, familiarly known as "the aerial doodle bug" to those entrusted with its closely guarded secrets, has been credited with being an important weapon in the crucial struggle which was waged against enemy submarines.

In its peacetime application, the new device fulfills a long-standing dream of geophysicists in that it provides means for a quick large-scale survey of geological structure which scientists feel may be an

important key to our natural resources. It is expected to be especially valuable in such now inaccessible areas as polar regions, jungles and offshore tidewaters.

The device was developed by Bell Telephone Laboratories in cooperation with the Naval Ordnance Laboratory under the auspices of the Navy's Bureau of Ordnance and Bureau of Aeronautics. Other magnetometers were developed by Gulf Research & Development Company, working independently and later under contract with the National Defense Research Committee, and by Columbia University Division of War Research through its Airborne Instruments Laboratory, also under contract with NDRC.

The method is considered so promising that those in charge of Naval Petroleum Reserves have employed it extensively in exploring for geological structures which may contain oil. Some 40,000 square miles in this country and Alaska, including part of the latter's Naval Petroleum Reserve Area No. 4, have already been mapped.

The instrument will also be used by the U. S. Geological Survey in mapping national resources and the U. S. Coast and Geodetic Survey has expressed the hope that further development might make possible the first really accurate magnetic map of the world.

Scientists associated with the development emphasized the reconnaissance nature of the device and pointed out that its chief value lay in its capacity to outline rapidly those areas which are promising, and which should be more intensively investigated by ground parties. In this connection, they pointed out that the magnetic airborne device

Submarine Stalker Now Seeks Oil

does not actually detect oil deposits, but by mapping geological structures, indicates those areas in which oil is usually found.

The new device is the latest in a long list of wartime developments, such as radar, improved communications systems and computing machines, which although developed primarily for war, are expected to have widespread peacetime applications.

The principal feature of the new system is an airborne magnetometer, or "measurer of magnetism," which found great utility during the war because it could detect the great masses of iron in submarines when they were submerged too deeply for ordinary aerial observation.

Just how sensitive the device is can be appreciated from the fact that during the research a new employee of Bell Telephone Laboratories inadvertently caused considerable confusion when she neglected to mention that a small bit of sewing needle which had broken off in her finger some years before had never been removed.

Extreme precautions had to be taken throughout the researches, even to the extent of using only brand-new, non-magnetic tools. At times the workers had to conduct their experiments in special clothing and in stocking feet, for some garments have metal accessories and shoes have nails. Even dirty finger nails have been known to disrupt the progress. Similar rigid precautions—almost surgical sanitation in effect—were observed in the production phase by the Western Electric Company, manufacturing associate of the Bell System, which produced several hundred systems for the Navy.

For its peacetime role, the Bell Laboratories-Naval Ordnance magnetometer was revised somewhat and combined with SHORAN, a radar mapping device developed during the war, and special mapping cameras under the direction of Dr. L. H. Rumbaugh, chief of the research department of the Naval Ordnance Laboratory. Geophysical applications have developed from plans worked out jointly by Dr. Rumbaugh and J. R. Balsley, Jr., of the U. S. Geological Survey of the Department of the Interior. Research and development work at Bell Telephone Laboratories was under direction of W. J. Shackleton, E. P. Felch and W. J. Means.

The first successful use of the new system of instru-

(Continued on Page Fourteen)

Headpiece: Photo by Bureau of Aeronautics.

TAKE A LOOK AT THE RECORD...



You can't tell by *looking* at a recording blank whether it will give you faithful reproduction. You can't tell whether there'll be surface noises or disturbing influences. *But . . .* just listen to it on the turntable. That's what top studio engineers have done . . . and that's why more and more of them are regularly specifying Advance Recording Blanks. The next time you're in the market for blanks . . . try Advance . . . and you, too, will be writing us love letters.

Advance
Recording Products
Company

36-12 34th STREET • STILLWELL 4-7837 • LONG ISLAND CITY, N. Y.

The Broadcast Engineers' **13** Journal for February, 1947

Latest Television Camera Control and Switching Equipment

THE new RCA television camera control and switching equipment, designed for both field and studio use, is made up of suitcase-type units for easy portability. The number of units required depends on the number of cameras being used.

Starting with the basic component of one camera, four pieces of equipment are necessary—one camera control, one power supply, and a synchronization unit made up of a pulse generator and a pulse-shaping equipment.

The camera control contains, in addition to the control circuits for the camera, a seven-inch high-quality viewing monitor and a three-inch oscilloscope. Camera driving pulses are generated in the camera control unit and transmitted to the camera through the connecting cable, which may be as much as 500 feet in length. A video amplifier which is incorporated in the control unit feeds the camera signal by coaxial cable to either the microwave link transmitter or, where more than one camera is used, to a master monitor.

The power supply unit takes 110-volt, 60-cycle power from almost any standard outlet, and regulates it electronically to eliminate the effects of line voltage fluctuation. The total current drain for a camera and camera control unit is only 8.5 amperes.

The pulse generator, which provides the standard sweep frequencies for the camera, has a self-contained power supply for its operation and that of the pulse-shaping unit. The latter includes circuits for generating the blanking and synchronization voltages from the master pulses. These two units can be used with one or more cameras. A synchronizing generator of this type can also be used as part of the test equipment of television receiver manufacturers.

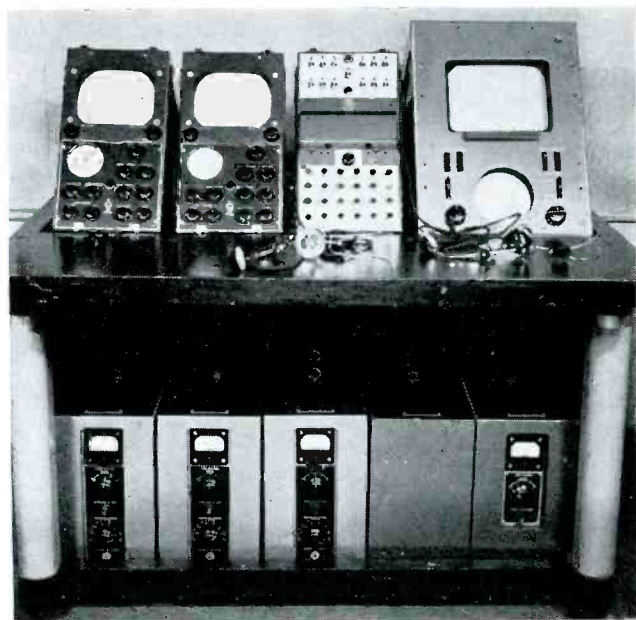

Portable RCA camera control and switching units required to operate two television cameras are shown mounted on a desk for studio operation. The units on the top of the desk are, from left to right, two individual camera controls, a master switching unit, and a master monitoring unit. The units under the table (which require no adjustment during operation) are, from left to right, two individual camera power supplies, a master power supply, a pulse-shaping unit, and a pulse-forming unit.

Generally, two cameras are used for field pickup, and the addition of a second camera necessitates five more pieces of portable control apparatus. Two of these units are the regulated power source and the monitoring and amplifying unit for the additional camera. The other equipments which must be added are a master control unit, a switching unit, and a power supply.

The master control unit provides for adjustment of deflection and blanking. A ten-inch high-quality picture tube provides for monitoring of the picture transmission, and a five-inch oscilloscope allows for adjusting the signal level and synchronization. From this point, the video signals are relayed by coaxial cable to the RCA microwave transmitter and beamed to the television station.

The switching unit provides for changing from one camera to another with as many as four cameras in use, or from remote pickup to film or studio. It also serves as the center of an intercommunication system which enables the program director to supervise all actions of cameramen, announcers, and other personnel, in some cases located as far as 500 feet away.

When the control and power units are used in the studio, they can be mounted on tables or slid into console-type racks which are equipped with casters for easy moving.

The entire equipment can be transported to a field pickup location in a station wagon or a light truck. If a truck is used, the monitoring equipment, power units, and synchronization generators can be mounted on built-in tables and racks and operated from the truck. With a larger type of truck, it is possible to transport a gasoline engine power supply for pickups where no utility power line is available. It is sometimes found advantageous to mount the microwave transmitter on the roof of the truck for transmission to the studio. Because of the portability and ease of installation of the equipment, it can easily be used in the field and then taken back and set up in a minimum of time in the studio for a studio presentation.

Submarine Stalker

(Continued from
Page Twelve)

ments occurred in tests conducted in Iron County, Michigan, and later in the Adirondacks in a search for iron ore deposits for war use. Subsequent tests indicated that in addition to its value as a speedy preliminary survey tool, the new device also gives a more accurate appraisal of the geological structure of an area than that obtained by ground parties using conventional methods of magnetic exploration. Another advantage of the new device is that it draws a continuous magnetic record of the terrain over which it is flown and in so doing disregards small and relatively unimportant magnetic irregularities.

The new instrument may also be used by oceanographers and geologists in the study of offshore geological conditions.

Humor—Re NBC's intention to ban hypnotists from television, John Royal, Tele/vp is reported as saying, "If people go to sleep watching our shows, it will be from natural causes, not because of hypnotism."

NABET Activity

(Continued from
Page Three)

the exchanging of ideas and the discussion of common problems will be best served by the formation of an inter-union council by the Los Angeles region radio workers; that we, the undersigned collective bargaining agencies representing these radio workers, will and do mutually found, assume an active part in, and carry out the aims of the aforementioned council;

PARAGRAPH TWO: That the scope and power of the Council shall be mainly advisory in nature; that the Council, for the most part, shall devote itself to the best interests of the contracting parties by advising the various union memberships of problems, common or particular, to the industry and its workers; that the Council is here empowered to discuss pending problems and, with the express consent of the guild or union in each instance, to advise and recommend suitable corrective action to the various general memberships; that the Council is empowered to facilitate the exchange of ideas and pertinent knowledge for the betterment of all contracting parties;

PARAGRAPH THREE: That this agreement is entered into for the purpose of furthering the general interest of the various bargaining groups concerned. The Council may not take any action which shall or may interfere with or infringe upon the autonomy of the respective guilds or unions constituting the Council. If at any time an individual union does not care to continue as a member of the Council, it may withdraw by presenting written notice to the Council. No decision of the Council shall ipso facto be a decision of the constituent guilds and unions, nor shall it require action of any kind by the guilds or unions except upon subsequent ratification, or prior authority in writing granted to the delegate, of and by the respective guilds and unions.

PARAGRAPH FOUR: That the Council shall consist of three (3) duly authorized delegates representing each of the contracting parties; that each of the contracting parties shall have one vote in the proceedings of the Council; that the three delegates representing each of the contracting parties shall vote as a unit in casting the vote of their organization; that the Council delegates elect by secret ballot from their number the following: a chairman, a vice-chairman, a secretary-treasurer; that the Council itself shall decide the powers, terms and general characteristics of these several offices; that the nature of the internal organization and operation of the Council shall be decided on by the delegates themselves;

PARAGRAPH FIVE: That the various contracting parties here represented finance the cost of the Council by contributing an initial sum of \$10.00 each to the Council treasury; and any additional sums of money as may be agreed on by the delegates at intervals specified by the delegates;

PARAGRAPH SIX: That this agreement shall be morally and ethically binding on the contracting parties in the persons of the signatories representing the various bargaining groups concerned; that this agreement may, by a majority vote of the Council members, be amended, revised or otherwise altered to conform with the wishes and decisions of the contracting parties.

The following additional paragraph is suggested by the Radio Directors Guild:

PARAGRAPH SEVEN: On a vote of a majority in number of the delegates, representing not less than a majority of the constituent organizations, the Council may admit to membership any bona fide collective bargaining agent for employees in the radio industry representing employees some or all of whose services are rendered within the County of Los Angeles. Each constituent organization holds its right to membership at the will of the Council. After reasonable notice and an opportunity to be heard, the Council may by a vote of a majority of the delegates (excluding the delegates of the organization which is being tried) expel any constituent organization, suspend it, or attach conditions for its continued membership. No organization which has for any cause whatever ceased to be a member of the Council shall have any property rights or any rights whatever in the Council or its assets.

James H. Brown

Vice-President, NABET

NBC-ABC network negotiations set to start March 4th.

Negotiations at WOR have been started January 14th, and postponed to February 10th.

Negotiations started January 9th on the third RCA-Victor contract.

NBC Sound Effects staff voted to join NABET at a recent NLRB election — unanimously! — Welcome! Negotiations started January 20th.

National Representative Gorsuch was in Durham, N. C., in connection with the dispute there, and has left for Washington to consult with NABET's attorneys.

DEADLINES: Still the same, i.e., the second of the month preceding month of issue. Example: copy must be received in Richmond Hill not later than March 2nd for the April issue.

GOSSIP COLUMN SPACE: Occasionally we are confronted with the misconceived notion that gossip column space not used in any issue or issues, is automatically "saved up" and that when the spirit so moves, the columnist may send in unlimited quantities and insist on its publication. At a recent meeting of the Journal's Board of Trustees, they unanimously went on record that Chapter gossip column space is not cumulative; i.e., space not used for columns is given over to other material. There is no way of "saving" space — just like time!

ZONE NUMBERS: Neither NABET nor the Journal assumes any responsibility for non-delivery or delayed delivery of the Journal unless the reader has given the Journal his Post Office Zone Number.

CUEING controls may now be ordered as standard equipment on any type of Daven attenuator, although most suited for mixing controls which are provided with a taper to infinity. The object of the cueing control is to permit the sound engineer to "spot" records and transcriptions before fading them in, monitoring incoming circuits for fade-in cues, etc. The terminal board of the attenuator is provided with an additional terminal

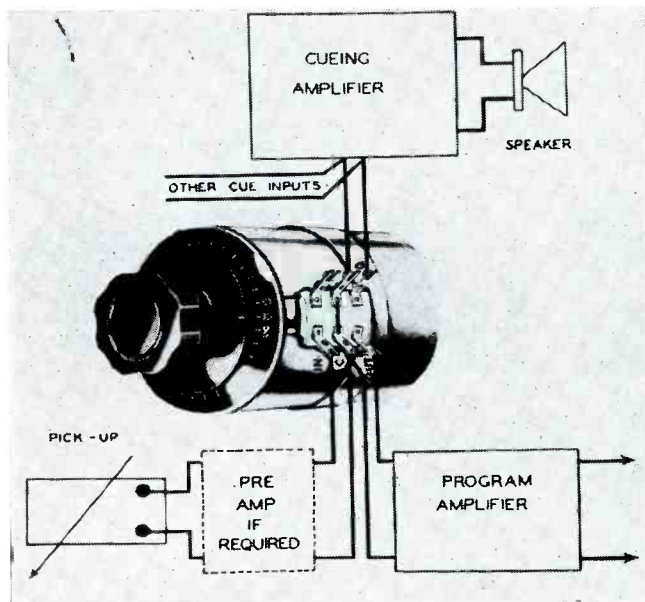

for connection to the input of a cueing amplifier. When the attenuator is in the extreme "off" position, the cueing circuit is automatically cut in. These direct cueing controls have wide application in broadcast stations, recording and transcription play-back, wired music service, and the sound film industry. Additional information may be obtained from the Daven Co., 191 Central Ave., Newark 4, N. J.

* * *

RMA reports over 27,000 FM receivers produced in Nov., an increase of about 11% over October.

Photoelectricity

(Continued from
Page Eleven)

Scanning is accomplished by converting the subject picture into the charge distribution explained above. The mosaic is then scanned by electronic means.

The beam of electrons used for scanning is generated and formed by a conventional electron gun located in the neck of the iconoscope (figure 5). When the electron beam strikes any part of the mosaic, secondary electrons are released. The number or amount of such electrons will depend upon the potential at that point which, in turn, depends upon the light intensity at that point.

Secondary emission current generated by the scanning beam represents successive values of image brightness (or darkness). And this is the complex, carefully timed television signal which is then amplified by later stages of the equipment.

Sensitivity of this basic iconoscope can be increased by *back lighting*. Using small flashlight bulbs, the glass walls and rear of the mosaic plate are slightly illuminated, without permitting spurious light to reach the sensitive side of the mosaic.

When the mosaic has been silver sensitized, the color or frequency response is similar to that of panchromatic negative-film emulsion used in motion pictures.

Improved types of television pick-up tubes have been developed. Chiefly: the *image iconoscope*, the *orthiconoscope*. But the operating principle of the basic iconoscope was not retained in these later, more advanced television tubes. While these mosaics are capable of emitting secondary electrons, these more sensitive television pickup tubes are not operated in this manner, and further discussion of these tubes is beyond the scope of this article.

Photoconductive Cells

All of the phototubes previously described are electronic in nature of operation. Current flow is caused by emission of electrons from a photosensitive cathode surface.

This process is known as photoemission, and is accomplished by phototubes.

However, there are two other means of light conversion which, while not too popular, deserve mention because of their unusual nature of operation: using *cells*.

Photoconductive cells are composed of a substance known as selenium. The resistance of this material varies according to the amount of light waves falling upon it. By connecting a battery or other d-c generating device in series with a cell composed of selenium, current flow can be controlled according to the intensity of the light waves incident to the cell.

Current varies as the square root of the illumination. Current is not linear (as for phototubes), and is not at all constant during long periods of operation.

Further: selenium cells are very sluggish in operation, and do not recover rapidly during quiescent periods. They have very little frequency (color) discrimination characteristics, but are more sensitive to ultra violet than to red light waves.

Photovoltaic Cells

Contrasting with phototubes and with photoconductive cells which both require a battery (or d-c source) for operation, *photovoltaic cells* in themselves function much like a battery when exposed to light waves of any frequency.

A photovoltaic cell is essentially a piece of oxidized

copper submerged in a solution of lead nitrate, with a lead electrode as the second terminal of the chemical device.

The cell develops an electro-motive-force which will vary according to the variation in intensity of light falling upon the copper-oxide terminal. As the frequency (color) of the light increases, the response of the photovoltaic cell decreases. But if the external load resistance is small, the response of this type of photoelectric cell is substantially linear.

Tubeless FM Converter

Tubeless FM Converter. Henry R. Kaiser, Chief Engineer, WWSW, Pittsburgh, describes a simple FM converter, to permit old FM receivers operating in the low band to receive FM stations in the new high-band. In the circuit shown, L_1 connects to the

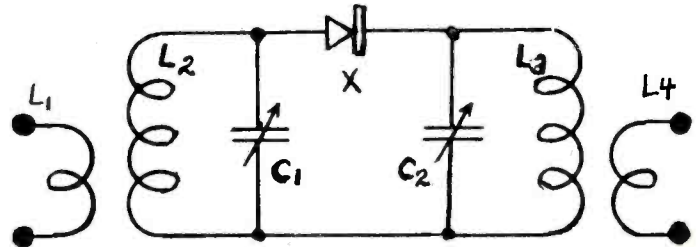

transmission line on the new band antenna. C_1 and C_2 are 8-plate midget air trimmer condensers. L_1 is 2 turns of No. 18 wire interwound with L_2 , and L_2 is 4 turns No. 10 solid enameled wire, space wound and self-supported. $7/16$ th inches diameter. L_3 is like L_2 , but 10 turns. L_4 is interwound with L_3 , 3 turns of No. 18. The crystal indicated at "X" is a Sylvania 1N34. L_1 connects to the antenna terminals on the old-band receiver. Mr. Kaiser says this converter was developed for their Pittsburgh audience, and avoids the excessive drift common to some of the one-tube converters. The input circuit $L_1 - L_2$ is tuned to the transmitter frequency, and the output $L_3 - L_4$ is tuned to a frequency in the old band. This latter frequency is the result of radiation from the local oscillator in the old-band receiver mixing with the transmitter frequency and producing a converter output signal which falls in the range of the old band. The entire converter is mounted in a small shield can.

* * *

Presto Exhibit



One of the outstanding exhibits at the recent Broadcasting Convention held in Chicago, was the display of new Presto recording and amplifying equipment. Highlighted were the Presto Recording Corporation's new type 8-D and 14-A Recording Machines.

Crystal Ball Dep't

The Journals addressed to the following are undeliverable by the United States Post Office, for the reasons stated by the Post Office on P. O. Form No. 3547, as follows:

- M. Jacobs (Hollywood)—moved.
 W. W. Fidler (New York)—moved, left no address.
 R. J. Clements (New York)—moved.
 R. Griffith (New York)—moved.
 J. C. Kerstetter (New York)—moved.
 M. Rhodes (Engineering)—moved.
 A. C. Gresens (Rochester)—moved.
 Lt. J. Shannon (Hudson)—moved, left no address.
 J. W. Downs (Chicago)—not there.
 O. H. Oliver (Richmond)—not there.
 W. Pooler (New York)—unclaimed.
 W. S. Carson (Engineering)—moved.
 H. Johnson (Denver)—moved.
 R. Grammes (Hollywood)—moved.
 R. Spivey (Atlanta)—moved.
 J. Craig (Hudson)—moved.
 John Kennedy (New York)—moved.
 P. Lynch (Phila.)—moved, left no address.
 E. Kahn (Engineering)—moved.
 H. Reynolds (Chicago)—moved.
 J. Connor (New York)—moved.
 R. Hawkins (San Francisco)—moved, left no address.
 D. E. Nickels (San Francisco)—moved, left no address.
 W. C. Prather (Chicago)—moved.
 H. J. Geist (New York)—moved.
 T. O. Crimmins (Syracuse)—moved.
 C. Lewis, Jr. (Mohawk)—moved.
 Miss Langley (Hudson)—moved.
 P. J. Foody (Phila.)—moved.
 Roy Harris (Denver)—moved.
 G. S. Dutton (Denver)—moved.
 B. Dobbins (Denver)—moved.
 P. L. Obluda (Denver)—moved.
 C. W. Nesbit (Denver)—moved.
 C. McElroy (Denver)—moved.
 R. L. Besser (Hollywood)—moved.
 R. W. Shover (San Francisco)—moved.
 J. C. Curry (Atlanta)—moved.
 M. Stillman (Rochester)—moved.

FM and Television antenna, transmission line, and splicing tape, of high efficiency is announced by Technical Appliance Corp., Flushing, N. Y. Enamel-finished steel tubing is used for supporting members. The dipoles are of aluminum; shipped knocked down, ready to assemble.

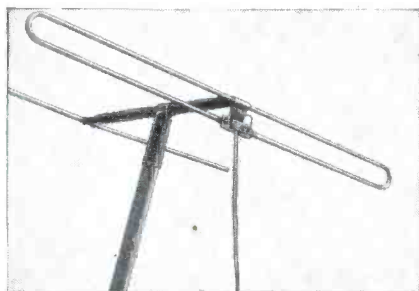

FOR TRUE

SOUND REPRODUCTION

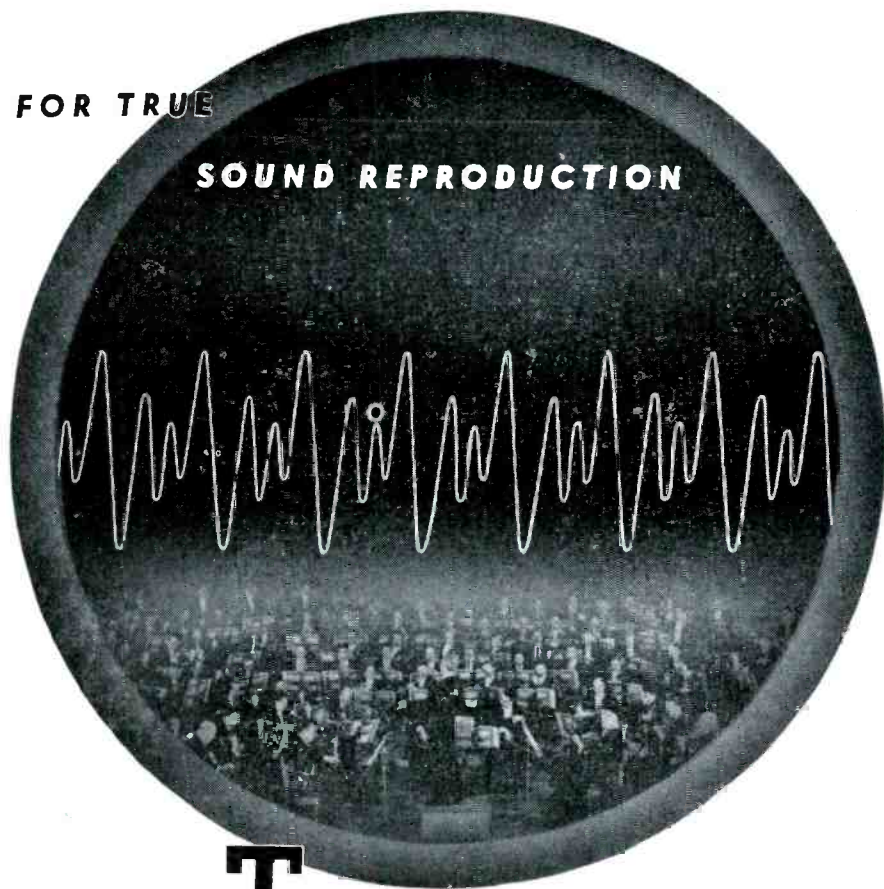





TERMINAL

SPECIALISTS IN ALL HIGH QUALITY
 SOUND EQUIPMENT

It's results that count and that's why the **TERMINAL RADIO CORPORATION** is the leading supplier to broadcast stations, recording studios, sound engineers and other users of high quality sound equipment.

Now Available for Immediate Delivery!

- 
PICKERING Pickups, Equalizers and Preamplifiers. Pickering's is the **only** pickup which satisfies FCC standards for FM broadcasting. Acclaimed by top-notch sound engineers as the finest reproducer for lateral-cut phonograph records and transcriptions.
- 
ALTEC LANSING Speakers, Cabinets and High Fidelity Amplifiers. Chosen by leading radio stations, motion picture studios and auditoriums, Altec Lansing is now available through the Terminal Radio Corporation to studios and high fidelity enthusiasts.
- 
RADIOTONE Portable Transcription Two-speed 16 inch Recorders. Radiotone Hollywood's new improved portable recording equipment is probably just what you've been looking for. Now available in several models for high quality disc recording and dubbing.
- 
AUDIO DEVICES Audiodisc aluminum and glass base Recording Blanks. **Audiobiscs** are high quality, precision-made instantaneous recording blanks which have won the praise of professional and amateur recordists. Designed for all high fidelity recording applications, available in sizes up to 16 inches.

As distributors for these and other high quality audio equipment, the **TERMINAL RADIO CORPORATION** can fill your high fidelity sound requirements.

Visit our Sound Studio to see and hear the newest equipment or write us for descriptive literature and prices.

TERMINAL RADIO CORP.

85 CORTLANDT STREET, NEW YORK 7, N. Y.
 PHONE WORTH 2-4415

Towers Tumble

As Science Marches On

THE RCAC paper Relay reports the dismantling of the world-famous long wave towers at Bolinas, Calif. And with the dropping of the three big masts that supported the antenna system for the Alexanderson Alternator, "30" finally comes to another important chapter in the history of radio communications.

At the outset of the war, the Navy found that its own high power, low frequency station at Hawaii, was inadequate to handle the war load of Pacific traffic. RCAC was called upon, and the Bolinas long wave equipment, which had been out of service for some time, was quickly rehabilitated and handling Navy traffic around the clock.

Those of you who have stood watch in the same building with an Alexanderson Alternator will understand the lusty cheering of the Bolinas staff when they received word that the Navy was relinquishing its operation of the Alternator! No more jumping on your car with both feet to avoid an unexpected jolt, or avoiding wire fences which snapped at you on oc-

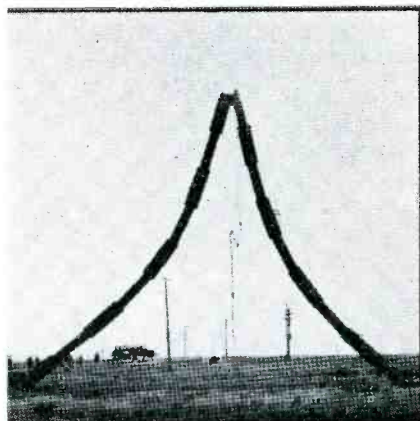

Down, but not completely gone. This mast tried to hold up its end of things and the inverted "V" had to be cut down.

casian; remember the sound of the machine coming up to speed, and the gear-box noise, the pounding of the keying contactors—and the sudden silence that accompanied a traffic lull?

It is well to remember that in this modern war of radar, VT fuses, VHF, etc., the Alternators put a steady signal thru where nothing else would,

and dependably—no skip, no fading. The Alternators didn't make the headlines, and thousands of tons of Instruction Manuals weren't written about them. The performance record of the Alternator and its dependability had



Looking across the triatic from the top of one of the 300-foot Alexanderson Alternator antenna masts.

been established a generation before.

Personally, we do not regard the de-activation of the long-wave Alternators with the sorrow that might attend the dropping of a 10kw transmitting tube; we feel, instead, that the Alternator has once more proven its worth, and that even though de-activated once again, it will be ready to perform again—if and when. In the meantime, our most humble respects to Dr. Alexanderson and his faithful Alternator! —EdS.

RCA Commercial Engineering, Tube Dept., Harrison, N. J. announces a new 16-page booklet "Receiving Tubes for Television, FM, and Standard Broadcast (Form 1275-C)" at 10c, either directly or thru RCA Tube Distributors. A completely revised and compact ready tube reference.

* * *

G.E. announces a new VHF power tube, type GL-5513, with a 2 kw output rating. Designed for television and FM applications under Class B and Class C conditions, up to 220 mc. In grounded-grid service, Class C telegraphy, the tube has an output of over 2 kw with a power gain of 10. Additional information: G.E. Tube Dept., Schenectady.

West of —You-Know-Where

By Pat Miller

I KNOW what causes all the line trouble west of Denver. As a matter of fact I have the trouble area well pinned down. Years ago I used to work for KPO-KGO and during my stay there I noted that all trouble was traced to an area east of Salt Lake. Thus I feel it wasn't illogical for me to assume that the trouble laid between Salt Lake and Denver and to act on this assumption. Awhile ago I sent an agent to the area to see what he could find out. He came back with the following data.

First of all, the sector is a very wild, inaccessible craggy land. The few people that live there are mostly frustrated account executives and other fugitives from Serutan commercials. They are really a kindly group that share their meagre fare with the wild bucks, mountain goats and lost sheep that wander dazedly through the canyons.

Though they get along well together they are extremely hostile to outsiders until they are satisfied that the interloper is not a representative from the Hooper rating people. Once my agent got into their confidence, they quickly let him in on their crusade. They promised to take him on what they called one of their raids.

The morning of the raid they brought forth their cache of arms. These consisted of cutting pliers, hacksaws, woodsaws, B-B guns and termites.

When all was in readiness they began their long arduous trip, taking my tenderfoot agent in tow. Arriving at the transcontinental phone line just before sunset, they took cover behind a clump of pines. While waiting for darkness, they took pot shots at the phone pole insulators. Dozens of the green glass eggs fell shattered victims of the eagle eye of a former production man from Ruthwolf & Lyon.

Under the cover of darkness, the group went to work. First came a long-term project called "Operation boring from within." This consisted of boring fine holes in the poles and pushing in the termites. Then another job consisted of carefully sawing through some poles until they were no longer poles but rather shaky Damoclean symbols of same. This took great skill, but a former playhouse engineer had a magic finger for this type of work.

After this careful work, a short sup-

per, and then to the blitzkrieg. A small portable radio was tuned to the offending network and as soon as the worst show came on, the stop watches were set. The short theme leading into the longwinded commercial in bad taste was allowed to come through but before the huckster could open his yap to tell of all the virtues of his client's product, a whistle blew and the team scampered up the poles and snip, snip, they went with the cutters. With this done, they scattered like a group of wildcats.

The leader told my agent that they time their raids according to the speed with which the phone company crews get the damage patched up. I was surprised to hear that the rebels even have agents in the phone company itself. These agents visit the rebels every summer during their vacation period. During their stay they are indoctrinated as to latest means of getting and keeping programs off the air. During their leisure periods the group have the phone men keep in trim by having them run races with some of the domesticated bucks. If the phone man beats the buck (this often happens) he is awarded a medalion on which is inscribed, "All honor to Argyle P. Flako, who on this day succeeded in passing the buck."

RCA-Victor has entered the coin-machine field, and has announced a coin-operated RCA set at the recent Coin Machine Show held in Chicago.

* * *

KFAB, the CBS outlet in Nebraska, is now in operation with its new Westinghouse 50 kw transmitter. Previously, KFAB operated with 10 kw. Air-cooled tubes are used thruout, and in cold weather, the heated air is used to heat the transmitter building. There is no water cooling of tubes. All low voltage DC is obtained with copper oxide rectifiers, cutting down tube replacements. Only rectifier tubes retained are for the main high voltage rectifier.

* * *

What is believed to be a new record for long tube life was recently reported in a letter to the RCA Tube Dept from Roland W. Richardt, Chief Engineer of WSAU, Wisconsin. Installed more than ten years ago, a pair of RCA-872 rectifiers, working 16 to 18 hours a day in the transmitter, are still performing satisfactorily; total time in service is already past the 55,000 hour mark!

NEW
TECH-LAB
DEVELOPMENT

For **RAPID**
MEASUREMENT
OF
AUDIO FREQUENCY
GAIN or LOSS

TYPE 1A
TRANSMISSION
MEASURING SET

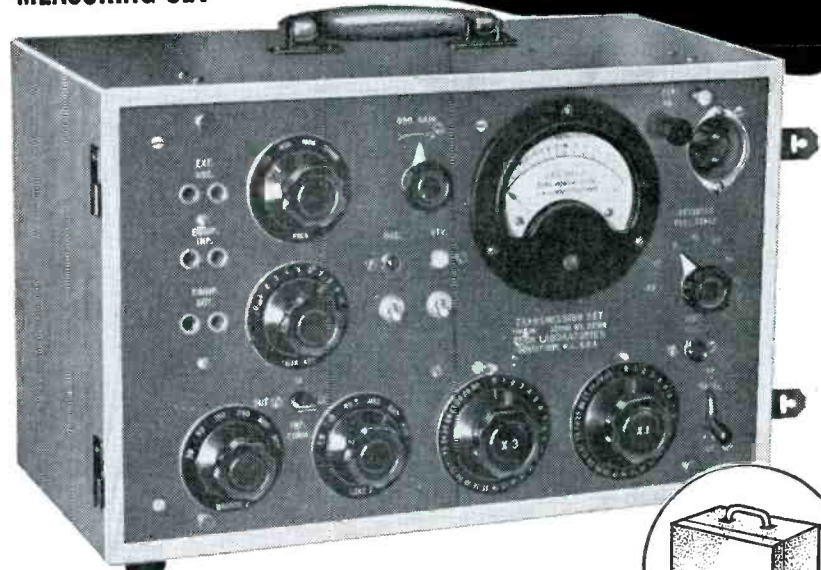

Completely Self-Contained
PORTABLE • AC OPERATED

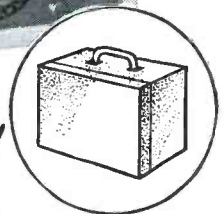

With this instrument it is possible to quickly and accurately analyze and service equipment in different locations without fuss in time consuming demounting and transportation of apparatus. It will thus pay for itself in a short time and no modern radio station can afford to be without it. It can also be used to good advantage in factory checking and inspection of audio equipment.

The set combines in a modern efficient manner an accurate vacuum tube voltmeter, an audio oscillator with four fixed frequencies and a precision attenuator all mounted in a handy cabinet easily carried by the operator.

SPECIFICATIONS

- GAIN: Up to 80 db.
- LOSS: 60 db. maximum.
- VACUUM TUBE VOLTMETER:
Range—40 to +40 db.
(1 mv. ref. level)
- AUDIO OSCILLATOR:
Freq. Range; 100 to
10,000.
- PRECISION ATTENUATOR:
Flat to 20 KC; 93 db.
in .1 db. steps.
- DIMENSIONS:
10 1/4" x 16 1/4" x 8 3/4"
- WEIGHT: 30 lbs.
- INPUT: 115 Volts.
60 cycles, 70 watts.

TECH
LABORATORIES, INC.

Manufacturers of Precision Electrical Resistance Instruments
337 CENTRAL AVE. • JERSEY CITY 7, N. J.

Gene "Dynamike" Clark of WOR

TWAS the year 1915 that ushered Gene down the ways to reality at Winchester, New Hampshire. His father who played fife in the drum corps saw to it that the town had a parade in honor of the arrival of his fourth son.

At the time one of Gene's brothers was studying the rudiments of violin playing and the trumpet, while another brother was doing right well doubling on the trumpet, sax, clarinet, violin and banjo. They saw to it that Gene filled the gap quickly by seating him on a piano stool at the age of one. This was only for atmosphere but at the age of two they were teaching him how to play scales.

When he was five he earned eight berries playing the piano at one of those summer square dances in the home town. The local belles swooned over this junior Duchin. Needless to say, this sold him on the idea of making music his career.

That fall he started school and rocketed along in meteoric style through grammar and high school garnering good marks with ease and acting as chief entertainer at all school functions.

Brother Wilton, owner of the first 201-a in town, adopted ham radio as a hobby with the call W2AYR. Gene soon became infected and raised the level of the neighborhood din with a Ford spark coil and a one tube blooper. During Gene's radio development he reached a stage where he could send the code well but was poor at copying it. He would sneak up to Big Brother's shack and call hams. But when he received a reply he would get panic stricken and tell the other ham that he had to rush off to work. However, he was soon caught when QSL cards started to arrive that his Big Brother couldn't account for in the log. Some speedy boning up on the code under his brother's baleful eye resulted in W2HTA and peace in the family.

In 1932 he left home and went to Hackensack, N. J., to join his brother's orchestra where they were playing a date in a chinese restaurant.

During this period he broke into radio doing piano and vocal bits on two Jersey locals, WBMS and WHOM. 1935 found him forming his own band and going to Kingston, N. Y., where they played the local theatres and clubs. Here while playing for a commence-

ment dance he met Emily Buzdygan, a gorgeous brown-eyed belle. He didn't know it then but ole debbil love germ had made with his entering wedge. Three years later he came down with a case of marriage.

Ye Ed still looks with a jaundiced eye on this marriage business but he might make the plunge if he could find Emily's double. Boy! What a crush I have. I held hands with her once and nearly swooned.

WKNY Kingston came into exist-



EMILY and GENE CLARK

tence in 1938, and Gene started parking on the manager's doorstep. He finally got a nibble when the Manager promised him a job if he obtained a first class ticket. Some brief homestudy and Voila! Gene's on the job.

Since he was president of the musician's local he filled in as staff pianist. When two announcers left he added verballity to his list of jobs at the plant. He indeed was a one man station where with keeping the peanut roaster on the air, riding gain, spinning disks, announcing, and playing Chopin preludes when necessary.

As a disc jockey he used to plug Sinatra's records as he felt that the lad had a future. Emily rounded out the musical Clark Family with a dulcet singing voice. Sinatra knowing this and hearing that Tommy Dorsey's vocalist and pianist were leaving, arranged to get the Clarks an audition but dog-gone if they didn't get cold feet and never showed up. Emily, however later worked with Jack Teagarden's Band.

WOR really got a find when they hired Gene in 1941. His musical know-how plus a sensitive artistic taste made him invaluable as a playhouse and big show man. Being a triple threat man in its truest sense, he certainly earns that pay check.

He decided a few years ago to learn the science of Chiropractic. He went to the Eastern Chiropractic Institute. Receiving the Degree of Doctor of Chiropractic, he was elected to deliver the salutatory address.

He won the Science Sidelights award for outstanding scholarship. He is now licensed to practice in two states, one of which requires that one pass The Basic Science Examination which is the same as taken by Medical Doctors. He now acts as a guest lecturer at the Chiropractic Institute of New York. He is not anti-medicine in his attitude. He feels that anyone who needs medical aid should go to a medical doctor but believes also that the Chiropractor has his job in the field and can care for ailments in his field with more success than medical doctors.

So what strange mixture do we have, fellers? Bone bender, pianist, and radio technician. Quite a combo! Ye Ed feels that there is a slumbering production man in the Clark breast too, But so far all my needling has been to no avail. I'm afraid he suffers from a deflated ego but Lord knows why. It seems some little man within keeps knocking the big man without. 'Tis true that some of us could use some of Gene's humility but it does him more harm than good. Yes, Gene, we are all for you. The radio business can use you in a post of much greater responsibility than you now hold. But I'm afraid its up to you, lad.

I don't know how that faint heart of yours won such a fair lady as Emily. Success too is a fair lady well worth getting, ya know. Gene says that Ham radio is his hobby as ever with 300 watts on ten meter phone. However, Ye Ed would like to say that if he was married to Emily he wouldn't need a hobby. Amen.—Pat Miller.

Audio Devices Film

Audio Devices now has a 16 mm full-color sound movie which depicts important phases in production of Audiodiscs as well as detailed information on the proper methods of handling and using Audiodiscs and Audiopoints. This movie has found wide interest, and is available for showing to groups of engineers and technicians, or a print of the film will be loaned to such groups when they have facilities for projection. For further information, contact Audio Devices, 444 Madison Ave., New York 22, N. Y.

Book Review

SPEEDLIGHTS by Arthur Palme, published by American Photographic Publishing Co., Nov. 1946, 128 pages, \$2.50, 5½ x 8 inches.

The author is an electrical engineer and ardent photographer. He relates the dearth of flash bulbs during the war, which caused him to look toward the speedlamp. Several commercial models and a home-made speedlamp are discussed, along with relative costs. The several chapters cover the whole subject matter and are titled:

1. Basic Principle and History of Highspeed Photography.
2. General Description of a Speedlamp.
3. Condensers and Flashtubes.
4. Commercial Equipment.
5. Synchronization Between Flash and Camera. Strobolight.
6. Comparison Between Photoflash and Speedlight.
7. Use of Speedlights.
8. Home Assembly of a Simplified Speedlight.
9. High-Voltage Warning.

The text is well illustrated, in addition to having a picture section demonstrating the types of action and what may be expected, and some interesting comparisons illustrating distortion resulting from high-speed focal-plane shutters. A complete bibliography is included. The text is well worth having.—EdS.

The A.I.E.E. Convention in New York reports improved television receiver design to obtain steadier and more brilliant pictures, and steady progress toward actuality of television networking.

* * *

Supreme Transmitter Corp., 280 Ninth Ave., N. Y. C., announces a new Ham transmitter, Model AF-100. Tech specs: 100 watt output, approx. 30" long, 12" wide,



19" deep; covers these ham bands: 10, 11, 15, 20, 40, and 80 for CW, ICW, AM and FM phone; continuously tunable throughout each band; band-switching throughout except for plug-in coil for the final stage. Operates on 110 v AC, consumes 325 watts, weighs about 125 lbs.



ALLIED

*The Name to Remember for
Quality in Recording Discs*

ORDERS SHIPPED PROMPTLY

ALLIED RECORDING PRODUCTS COMPANY

21-09 43rd Ave., Long Island City, N. Y.

Phone STillwell 4-2318

Cable: Allrecord, New York

Ed. Horstman—the Poor Man's Frank Buck!

DURING his vacation last summer, Ed Horstman, Chief Engineer of ABC's Central Division, made elaborate plans for a week's fishing on Lake Vermillion, near Tower, Minn. Early in August he packed rods and reels, an assortment of multi-colored flies, and headed north.

The first morning dawned on a day that even Isaac Walton would have envied. The weather was warm, the water calm, and the sky overcast. The lake was so clear, that schools of golden-olive, black-spotted muskellunge could be seen frisking in the depths below.

Presently, Horstman's attention was caught by sounds of splashing about a hundred feet away from his boat. He stared through the morning mist and saw, paddling toward him, a mother bear and two cubs, blithely unaware of the human cargo in their vicinity.

Horstman grabbed the oars and with a few rapid strokes overtook the three bears. He snatched up a fishing net and threw it over one of the cubs. The mother and her other, more fortunate offspring, did a double-beat Australian crawl back to shore.

Horstman christened the cub "Tar Baby" and soon became so fond of the animal that he obtained permission from the State of Minnesota to keep it.

A few days later he began the return trip to Chicago with Tar Baby securely enclosed in an enamel chilling unit with improvised air vents for breathing purposes.

For four hundred miles the cub whined with almost

human tones. The sound was so pathetic that Horstman stopped only once for food, and then only because Tar Baby momentarily lapsed into silence. He had hardly seated himself at the lunch counter when he heard the mournful wails vigorously renewed. He rushed out, started the motor and made the rest of the trip non-stop.

On arrival in Chicago, Horstman soon found that Tar Baby was not meant to be a household pet. Reluctantly, he placed the animal in a pen near the Station WENR trans-



ED HORSTMAN

Chief Engineer of ABC's Central Division

The poor man's Frank Buck! Ed Horstman, ABC's Central Division engineering chief, takes time out from his engineering duties to play with "Tar Baby," the black cub which he caught in a fishing net last summer while fishing on Lake Vermillion, Minn. "Baby" weighed 60 pounds when he was caught, escaped the following week, and was recaptured last week. He now tips the scales at 175 pounds.

mitter, 22 miles southeast of Chicago. On August 22, Tar Baby broke out of his pen, climbed a wire fence, and vanished in the wilds of Will County.

Stock joke around the network in the weeks following, was that Horstman's biggest one had gotten away. But one day early this week, Tar Baby was found up a tree in Orland Park, located about three miles from the WENR transmitter. With lassos, prods, and much wheedling, the bear was recaptured and placed in the pen (reinforced) he had deserted two months ago. Tar Baby had gained a hundred and fifteen pounds during his eight weeks' leave.

Horstman now regrets the impulse that first drew him to Tar Baby. During his escape, the animal lost its cuteness, developed a snarl, some very sharp teeth, and a bad disposition.

Says Horstman ruefully, "Tar Baby has become very unbearable."

for your work or hobby

NEWARK OFFERS YOU

Source of supply for all radio and electronic equipment and parts. Products of leading manufacturers in the industrial as well as home equipment fields. Complete stocks.

Through its Bargain Bulletins, the latest news about the latest developments in radio and electronic equipment. Get on the list to receive these valuable bulletins regularly.

Prompt, speedy delivery on orders. Expert and courteous advice on equipment and parts problems.

Complete stocks of all leading public address systems, plus able advice on setting up special installations.

Visit any one of our three large stores. You will find complete stocks of industrial equipment and parts as well as home appliance and radio equipment. Send us your name and address and ask for Bargain Bulletins.

★ MAIL ORDERS FILLED FROM EITHER NEW YORK CITY OR CHICAGO

NEW YORK
Offices & Warehouse
242 W. 55th St., N.Y. 19

NEWARK

CHICAGO
323 W. Madison St.
Chicago 6, Ill.

ELECTRIC COMPANY, INC.

New York City Stores: 115-17 W. 45th St. & 212 Fulton St. U2

News of Baltimore

By Alex Beauchamp

HERE we are, in the dead of winter again with everything frozen up tighter than a kettle drum. ~~Brrrrr~~—it's cold! People are walking along the street, with their heads pulled down in coat collars so far, you have to use a periscope to see where you are going.

The other morning while coming to work, I met a friend. He tried to tell me something, but I couldn't understand a word he was saying. The words froze into solid ice and hit the ground. I picked them up and carried them up to the transmitter to thaw out. It's just as well I didn't know what my friend was saying—he wanted to borrow a five spot.

Well, I know that story has whiskers, but I wanted to illustrate what often happens when a friend is asking for help and his pleas fall on deaf ears. It is a mighty lonesome feeling when you have to stand alone. To fight your own battles without anyone's aid. We can accomplish much more, banded together, than we can when we stand alone.

We have a strong, local organization, but we could be much stronger if there was a little more cooperation among our members. In unity there is strength, and, to attain unity we need the ability to work together.

Any organization, whether it's Fraternal, Labor or Social, needs Unity of the members to thrive and grow. When problems come before the officers, and they execute the laws of the organization, it's the duty of each and every member to carry out such orders, even though a few of the minority did vote against them. In a democratic organization, it's the majority that rules.

True, we are members of a labor union . . . a democratic union. Where all the members have equal rights. For we serve no demigods or any self-styled tsars. It is our own votes that ratifies the actions of our leaders. So, let us take stock of ourselves and make sure our own words don't fall into chunks of ice—to be melted later on when it is too late. Let us keep our heads up out of our coats, far enough to know where we are going—no matter how cold the temperature.

WITH

Bud Chell, our special events TE had an unusual on-the-spot program a few weeks ago, when WITH interviewed "BESS," the wonder horse, that appeared in M.G.M.'s "Gallant Bess." "Bess" can sign her autograph, tell time by a watch, answer yes or no to any question, and do many other amazing stunts. One of the amazing stunts performed by "Bess," was to get tangled in Bud's mike cord, and cut the program off the air two minutes early. She made her apologies for the abrupt ending of the show, no doubt.

The other night on his way to work, John Lappe was putting some letters into a letter box for the next collection of the mail. After depositing his letters, he realized he had mailed the wrong ones. To most of us, retrieving a letter from Uncle Sam's mail, would necessitate a trip to the main post-office, but to John, it's just a mere trifle. For John is about as large as a half-pint, but all man. All John did, was to reach up, pull the box open and crawl inside, sort the letters until he finds what he is looking for.

This is the sixth WITH Christmas party I've attended, and I've seen many new faces and have looked searchingly for the missing ones. The latest one on the list of missing at WITH is the assistant manager, Mrs. Helen Powers. Every member of the staff has lost a real friend. Whenever you would take your problems to Helen, she always got action on them. She was never too busy to take time out from whatever she was doing, to listen to you. No matter how distressing things were, she always had a smile for everyone. Helen has watched over many young fledglings that tried their first wings at WITH, then soar to greater heights in their professions. Now, it's Helen's turn to advance to a higher goal. Helen has taken a position as operation Manager and Program Director of WHHM, Memphis, Tennessee.

We are all proud of the wonderful opportunity offered her and know she will handle all affairs there as well as she did here. Congratulations to WHHM, and condolences to WITH.

(Continued on Page Twenty-four)

CAPPS*

SAPPHIRE is, and has always been, the only material for making cutting styli for high class recordings.

CAPPS* Patented Sapphire Styli (2187512) are the original and accepted standard for high class professional acetate recordings.

Imitated but not equalled

FRANK L. CAPPS & CO., Inc.

244 W. 49th STREET NEW YORK CITY

Telephone Circle 6-5285

* Reg. U. S. Pat. Off.

C O P I E S

**BY DIRECT CUTTING
OF YOUR RECORDINGS**

33 $\frac{1}{3}$ RPM transcriptions
for broadcast or audition
use.

24 HOUR SERVICE
—packaged and shipped
from Chicago.

Aluminum based material
available for broadcast use.

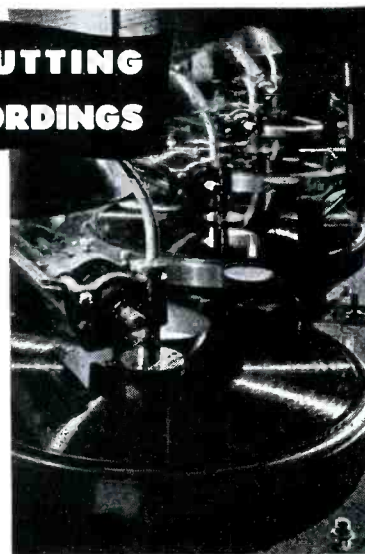

*Write for
complete
details and
prices.*

L. S. TOOGOOD
RECORDING COMPANY
221 N. LA SALLE ST. CHICAGO 1

Famous Quotes Re BC-375-E Transmitters

As Recalled by E. L. Parkhurst, W6IY

ANDRESEN, W6BRR, "—I Got what I wanted when I wanted it."

SUMMERS, W6ADO, "Who the——got my 375-E mike transformer?"

O'NEIL, W6GIS, "A veritable store-house of valuable parts."

PARKS, W6UO ex W6PSH, "—Wanted, One only, antenna tuning condenser from BC-375-E transmitter."

MARTIN, W6YBC, "Dear FCC. At the time mentioned in your recent citation I was operating——etc."

NICHOLS, W6WPL, "—does battery acid do THAT to clothes?"

SORENSEN, W6DZP, "—You know, I think the thing has possibilities."

PARKHURST, W6IY, "—what's a good solvent for Glyptal varnish?"

WOODS, W6WOK, "—how come it hums with A.C. on the filaments?"

SANDERS, W7—/6, "—I'll make the ——thing work, and on ten meters, too."

HILL, W7—/6, "—let me leave a thought with you."

BERNARD, W7BSK/6, "—looks good to me."

JEFFERSON, W6MY, "—how nice it looks in my living room."

MAXWELL, W6NXC, "—After one more transmitter I'll have to tear into——"

VAN WART, no call, "—makes a swell anchor."

CASSIDY, do., "—where can I get a concertina?"

WATSON, do., "—my agents tell me——"

HALL, do., "—more darn junk."

COOPER, W6——, "—more darn junk."

BLANK, (strictly a non-conformist, believe me) "—please enlighten me on the full concept of the expression quote signal yoops unquote."

AND FROM THE MANY, MANY OTHERS whose quips and quotes have been unlogged comes the UNANIMOUS CHORUS "—QST and JSS are RIGHT."

Baltimore News

(Continued from Page Twenty-three)

Robert C. (Jake) Embry, Vice-President of the Tinsley Enterprises, served as Master of Ceremonies at the WITH Christmas Party.

Jake informed the staff that 1946 was the most financially successful year in our history. He further stated that WITH was recognized as the largest, and the most progressive little station in the country.

Having the recognition of larger broadcast stations, WITH is able to secure top talent, such as Ian Ross MacFarlane, Newscaster, Bill Dyer, Sports-caster, Bill O'Tool and Snow-Ball, Bob Barry, who is waking up Baltimore these mornings and M. C. on "Laffs with Lunch."

Bob Barry is the latest addition to our staff and he hails from the big time. Bob has been in numerous plays and musical comedies, appearing on Broadway. Many of the plays in which he has appeared were: "Windy City," "Queen High," "Blossom Time," "Little Jesse James," "Too Many Girls," "Hollywood Hotel," "Gilbert and Sullivan Operas," "Room Service," "The Cat and The Canary," and "Susan and God." As a featured singer and em-cee, he played leading night clubs and hotels of this country and Canada, and has been vocalist for the Bobby Hayes and Billie

Swanson orchestras. He has also appeared as guest soloist with Ben Bernie and Abe Lyman.

Prior to the war, Bob was booked to play the lead in the musical comedy, "Hollywood Hotel" in which he toured the United States and Canada and then went to Australia, where he spent over a year touring the principal cities of both Australia and New Zealand. He has also played over the Keith and RKO picture house circuit and has made shorts for Warner Brothers in New York. We feel quite proud to have Bob with us, and from reports so far from the audience, he rates top with them.

I don't know what Bill Dyer is doing with all his secretaries, but he is advertising for a new, good-looking secretary. Bill's latest secretary, Maryan Bass, gave up her secretarial duties to become Mrs. Phil Nesbet, popular WITH announcer.

Ian Ross MacFarlane and his wife (the little girl in the big hat) are making a tour of Europe and the near East. They will visit Palestine, Ireland, Scotland, England and other countries in Europe. Before joining WITH, Mr. MacFarlane was a European correspondent, having covered the first phases of World War II.

Harold (Butch) Stockslager is busy swapping days off, so he can make week-end trips to court his girl friend, living in western Md. In making these trips, Butch doesn't know which beats harder and faster—his heart or his old flivver. If the flivver breaks down, there might be a busted romance.

WFBR

Here's a real scoop! Freddie Himes, MC, TE, is going around in circles, and looks like he's been hit by something—he is in a daze. Freddie has been hit, and it was cupid's arrow that found its target in his heart. I haven't located the lucky girl as yet, but will keep you informed as this romance progresses. I believe Freddie plans marriage in the fall. Oop! It slipped.

One of the transmitter Engineers wants the schedule changed at WFBR. The existing schedule has him working on Christmas day, for the next seven years. (Ed's note) An echo was also heard from one of the boys at WITH's transmitter shack.

A new program is being aired over WFBR's wavelength these days. The show is sponsored by "Scoop" and is known as "Shop in Fun." The master of ceremonies is none other than the biggest man in Radio (350 lbs. of him) Lonny Starr. (See page 102 of Yearbook). A great deal of fun is had by the audience, especially those that win gift merchandise.

We want at this time, to say that we were glad to have John Bourcier, member of the N. Y. field staff at ABC, who visited us several times when Sammy Kaye was appearing at the "Walnut Grove," here in Baltimore. John engineered the network feeds of Sammy Kaye. Bill Roche, our own announcer, announced the shows.

Any NABET Engineer who visits Baltimore is more than welcome to visit WFBR, and see a layout that is tops, south of the Mason and Dixon line.

"Song and Story" and "At Home With the Websters" are two more new shows kilocycling through the air when it is isolated from our tower in Westport. Both shows feature Gene and Ginny Webster blending their voices together and accompanied at the piano and organ by Carrol Warrington. (See page 88 of Yearbook).

They tell me that lightning never strikes twice in the same place, but it happened here, twice in one week, and it was the engineer that came through and saved the day when the morning announcer failed to show up for his usual assignment.

WCBM

Calling the WCBM studios to get a line from Larry Taylor, the other night, I was informed he had gone into hibernation for the season. The receptionist, with whom I was talking on the phone, asked, "if there was any message for Larry?" I said, "I only want to get the news items for the journal." She then said, "The company is giving turkeys to all the personnel for Christmas."

I would like to express my thanks to the receptionist for giving me the one and only item of news from WCBM for this month. To Larry, I present the bird, (not a turkey) for sleeping on the job again.

We also have a vacant spot in our heart for Larry, so we are reserving the remaining blank space on this page for him.

Original Recording For

BILLIONTH RECORD



... on **audiodiscs**

Recently in Camden, N.J., where the Victor Talking Machine Company was founded some 48 years ago, the billionth R.C.A. Victor Record was produced, thus marking a milestone in the history of the company, as well as the record industry.

For this history-making record, the Victor Division of the Radio Corporation of America chose two of John Philip Sousa's stirring marches, "Semper Fidelis" and "The Stars and Stripes Forever," played by the Boston

Symphony Orchestra under the direction of Serge Koussevitsky. And for the discs, on which the original sound recording was made, they chose Audiodiscs.

For the original sound recording in the phonograph record and electrical transcription industries—for master discs used in processing—for sound recording and reproduction in radio broadcasting and motion picture studios—Audiodiscs hold a place of eminent leadership.

AUDIO DEVICES, INC., 444 Madison Avenue, New York 22, N.Y.

Export Department: Rocke International Corp., 13 E. 40th Street, New York 16, N.Y.

Audiodiscs manufactured in the U. S. A. under exclusive license from PYRAL, Paris.



they speak for themselves **audiodiscs**

DAVEN

ENGINEERING LEADERSHIP

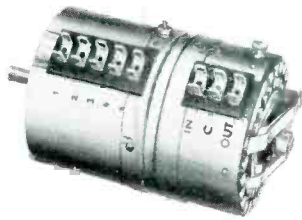

TONE COMPENSATING ATTENUATOR TYPE LAC-720

... frequency characteristics follow the hearing response curves of the human ear. Base frequencies have smaller loss than the middle or upper registers.
(Pat. Pend.)

Here are 4 of the more recent DAVEN "firsts". DAVEN long has been known for leadership . . . particularly in engineering and design. Many of our developments have been incorporated in the equipment of broadcasting stations, sound recording studios, and electrical laboratories throughout the world, and are specified as standard.

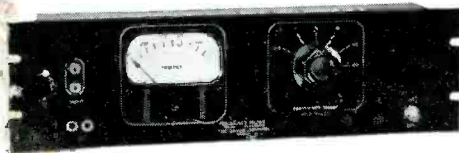

FREQUENCY METER TYPE 838

... frequencies read directly to 100,000 cycles with an accuracy of $\pm 2\%$ of full scale in use . . . 7 ranges available . . . low input voltage requirements . . . large, easy-to-read illuminated meter . . . mounted on a $5\frac{1}{4}$ " relay rack panel.

The DAVEN Engineering Department will be glad to discuss these new developments with you. Your inquiry is invited on the units shown or on any other DAVEN product.

THE **DAVEN** CO.

191 CENTRAL AVENUE
NEWARK 4, NEW JERSEY



TRANSMISSION TEST SET TYPE 8A

... a portable, 12-pound battery operated set . . . receiving amplifier measures levels down to -50 DBM . . . contains an internal 1000 cycle oscillator . . . can also serve as a bridging V.U. indicator with range of -40 to $+23$ V.U.

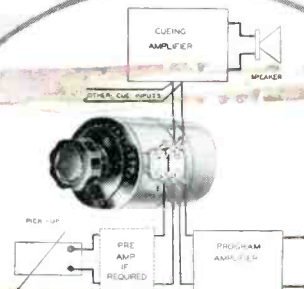

ATTENUATORS-WITH BUILT-IN CUEING CONTROLS

... eliminate the need for auxiliary switching mechanisms . . . also available with built-in switchette for a pilot light . . . may be obtained on Ladder, "T", Potentiometer, and Ladder Fader controls.
(Pat. Pend.)